

# HMS ENDEAVOUR “514” \*\*

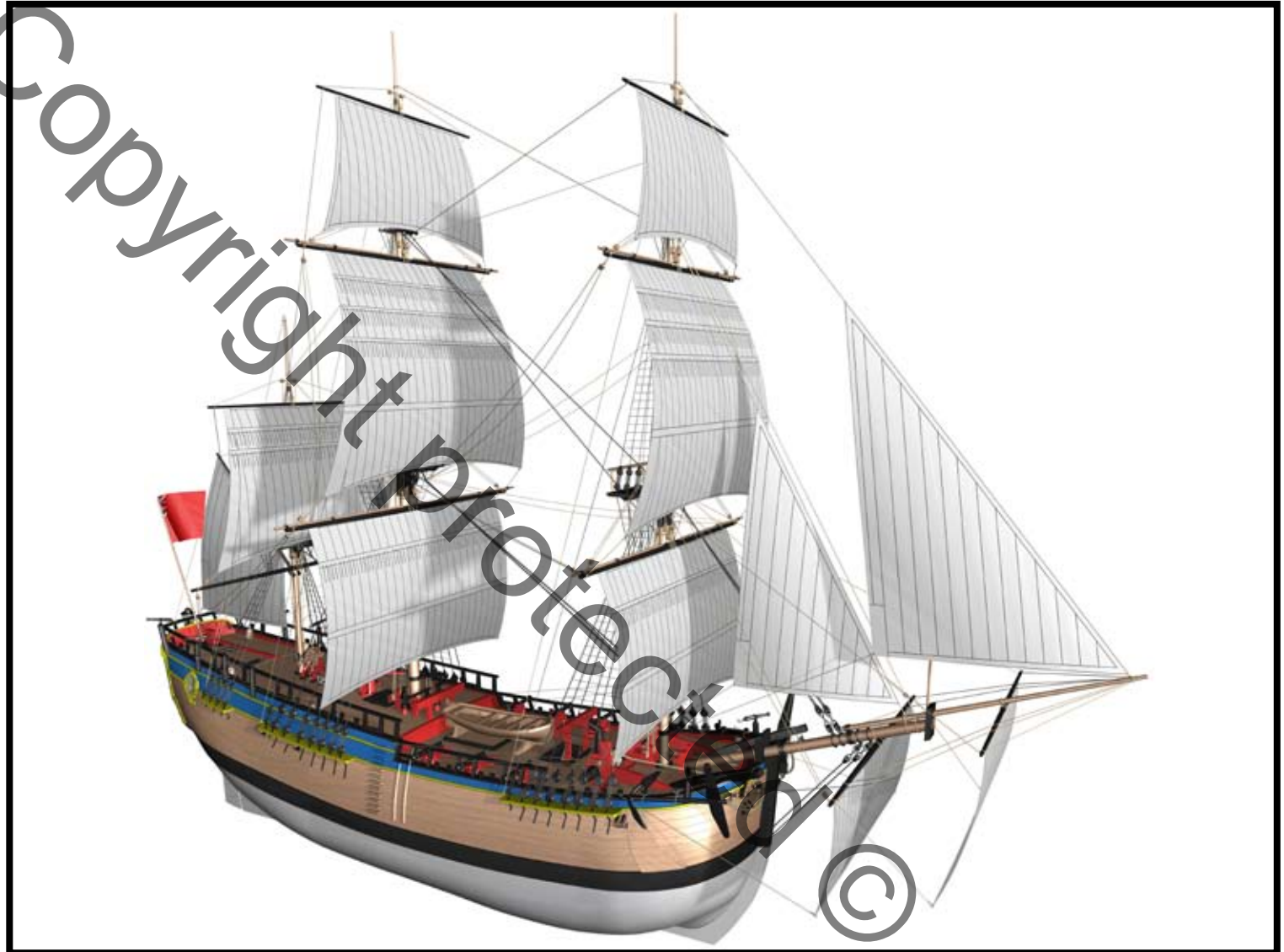

BUILDING INSTRUCTION

This model is Copyright protected.  
All Copyrights to the designs of this  
version of the HMS Endeavour belongs  
to Kreaan Holding Aps



[www.billingboats.com](http://www.billingboats.com)

DK

HMS Endeavour, også kendt som HM Bark Endeavour, var et britisk Royal Navy forsknings fartøj, som Løjtnant James Cook var befalingsmand på, på sin første opdagelsesrejse til Australien og New Zealand, 1769-1771.

Hun blev lanceret i 1764 som collier Jarl af Pembroke, og flåden købte hende i 1768 til en videnskabelig mission til Stillehavet og til at udforske havene omkring Terra Australis Incognita eller "det ukendte sydlige land".

Flåden omdøbte og bestilte hende som Hans Majestæt Kongen Bark Endeavour. Hun forlod Plymouth i august 1768 rundede Kap Horn, og nåede Tahiti i 1769.

Hun satte derefter sejl ind i et stort set uudforsket hav mod syd, stopper ved Stillehavsøerne i Huahine, BoraBora og Raiatea for at Cook kunne kræve dem for Storbritannien. I september 1769 lagde hun anker ud for New Zealand, det første europæiske fartøj til at nå øerne siden Abel Tasman's Heemskerck 127 år tidligere.

I april 1770 blev Endeavour det første skib til at nå den østlige kyst af Australien, da Cook gik i land på, hvad der nu er kendt som Botany Bay. Endeavour sejlede derefter nordpå langs den australske kyst. Hun undgik med nød og næppe en katastrofe efter grundstødning på Great Barrier Reef, og Cook var tvunget til at smide sine kanoner overbord for at gøre hende lettere. Han strandede hende på fastlandet i syv uger for at tillade rudimentære reparationer på hendes skrog. Den 10. oktober 1770 humpede hun i havn i Batavia (som nu hedder Jakarta) i Hollandsk Ostindien, for flere væsentlige reparationer, med hendes besætning som havde tavshedspligt om de landområder, de havde opdaget. Hun genoptog sit vestlige færd den 26. december og rundede Kap det Gode Håb den 13. marts 1771 og nåede den engelske havn i Dover den 12. juli, efter at have været på havet i næsten tre år.

GB

HMS Endeavour, also known as HM Bark Endeavour, was a British Royal Navy research vessel that Lieutenant James Cook commanded on his first voyage of discovery, to Australia and New Zealand, from 1769 to 1771.

She was launched in 1764 as the collier Earl of Pembroke, and the Navy purchased her in 1768 for a scientific mission to the Pacific Ocean and to explore the seas for the surmised Terra Australis Incognita or "unknown southern land".

The Navy renamed and commissioned her as His Majesty's Bark the Endeavour. She departed Plymouth in August 1768, rounded Cape Horn, and reached Tahiti in time to observe the 1769 transit of Venus across the Sun. She then set sail into the largely uncharted ocean to the south, stopping at the Pacific islands of Huahine, Borabora, and Raiatea to allow Cook to claim them for Great Britain. In September 1769, she anchored off New Zealand, the first European vessel to reach the islands since Abel Tasman's Heemskerck 127 years earlier.

In April 1770, Endeavour became the first ship to reach the east coast of Australia, when Cook went ashore at what is now known as Botany Bay. Endeavour then sailed north along the Australian coast. She narrowly avoided disaster after running aground on the Great Barrier Reef, and Cook had to throw her guns overboard to lighten her. He then beached her on the mainland for seven weeks to permit rudimentary repairs to her hull. On 10 October 1770, she limped into port in Batavia (now named Jakarta) in the Dutch East Indies, for more substantial repairs, her crew sworn to secrecy about the lands they had discovered. She resumed her westward journey on 26 December, rounded the Cape of Good Hope on 13 March 1771, and reached the English port of Dover on 12 July, having been at sea for nearly three years.

D

HMS Endeavour, auch bekannt unter dem Namen HM Bark Endeavour, war ein Forschungsschiff der Royal Navy. Auf seiner ersten Forschungsreise nach Australien und Neuseeland (1769 bis 1771) stand das Schiff unter dem Kommando von Lieutenant James Cook.

HMS Endeavour lief 1764 als der Kohletransporter Earl of Pembroke vom Stapel und wurde 1768 von der Royal Navy erworben, um den Pazifischen Ozean zu erforschen und nach der Terra Australis Incognita, dem dort vermuteten Südkontinent zu suchen. Die Navy benannte das Schiff um und stellte es als His Majesty's Bark the Endeavour in Dienst. Die Endeavour verließ Plymouth im August 1768, umrundete Kap Horn und erreichte Tahiti gerade rechtzeitig, um den Venustransit im Jahre 1769 zu beobachten. Anschließend setzte sie ihre Fahrt in den weitgehend unerforschten Süden des Ozeans fort. Im Verlauf dieser Reise landete Cook auf den Pazifikinseln Huahine, Bora Bora und Raiatea und nahm sie für Großbritannien in Besitz. Im September 1769 ging die Endeavour vor Neuseeland vor Anker und war damit das erste europäische Fahrzeug seit Abel Tasmans Heemskerck 127 Jahre zuvor.

Im April 1770 erreichte die Endeavour als erstes Schiff die Ostküste Australiens, wo Cook in der heute als Botany Bay bekannten Bucht an Land ging. Anschließend folgt die Endeavour der Küste Australiens nach Norden. Nur knapp entging sie dabei einer Katastrophe, als sie am Great Barrier Reef auf Grund lief. Cook musste alle Kanonen über Bord werfen lassen, um das Schiff wieder frei zu bekommen. Anschließend setzte er die Endeavour auf den Strand und ließ die notwendigsten Arbeiten am Rumpf ausführen. Am 10. Oktober 1770 erreichte er den Hafen von Batavia, das heutige Jakarta, um das Schiff fachmännisch instand setzen zu lassen. Die Besatzung wurde während dieser Zeit zum Stillschweigen über das entdeckte Land verpflichtet. Am 26. Dezember setzte die Endeavour ihre Fahrt nach Westen fort, umrundete das Kap der Guten Hoffnung am 13. März 1771 und erreichte schließlich das heimische Dover am 12. Juli nach fast dreijähriger Reise.

F

Le HMS Endeavour ou HMB Endeavour (Her Majesty Bark) est un trois-mâts carré britannique (le mot anglais bark ne fait pas référence à son gréement mais à la forme de sa coque). Il fut utilisé par James Cook lors de sa première expédition (1768-1771). Originellement conçu pour le transport de charbon, il est racheté et reconverti en 1768 par la Royal Navy afin d'explorer les mers du Sud et la mythique Terra Australis.

Le HMB Endeavour appareille de Plymouth en août 1768, formé d'un équipage de 94 marins dont 13 gens d'arme. Ses réserves sont prévues pour 18 mois, composées entre autres de volailles et d'une chèvre à traire. Le navire fait escale à Madère en septembre, à Rio de Janeiro, au Brésil en novembre. Le navire double, sans grandes difficultés, le cap Horn en janvier 1769. Cook et son équipage débarquent à Tahiti le 10 avril. Ils y restent durant trois mois, le temps d'observer le passage de Vénus, qui a lieu le 3 juin. Le 13 juillet, l'Endeavour quitte Tahiti. L'expédition croise ensuite l'archipel de la Société.

En octobre 1769, l'Endeavour atteint la Nouvelle-Zélande, terre découverte en 1642 par le navigateur hollandais Abel Tasman. Cook resta plus de six mois en vue de la Nouvelle-Zélande dans le but de la cartographier. Il en conclut que cette terre n'est en réalité que deux îles et non la Terra Australis tant recherchée. L'Endeavour continue son périple vers le sud-ouest pour atteindre Botany Bay (actuellement Sydney) le 28 avril. Le trois-mâts repart le 5 mai. Durant environ 4 mois, Cook cartographie les côtes de la Nouvelle-Hollande (ainsi était autrefois nommé l'Australie). En juin 1770, le navire heurte un récif. Les dommages causés à la coque sont assez conséquent. L'expédition se voit suspendue. Les réparations seront effectuées au niveau de l'Endeavour River, sur la côte australienne. Du 10 octobre au 26 décembre 1770, le navire fait escale à Batavia (Jakarta) pour réparations. C'est pendant cette escale qu'un grand nombre de marins décèdent de la malaria. L'expédition se clôture le 12 juillet 1771 avec le retour de Cook en Angleterre.

NL

HMS Endeavour, ook bekend als HM Bark Endeavour, was een Brits Royal Navy onderzoekschip dat onder bevel van luitenant James Cook op zijn eerste ontdekkingsreis, van 1769 tot 1771 naar Australië en Nieuw-Zeeland een tocht maakte.

Gedoopt in 1764 als het kolenvrachtschip Count of Pembroke, werd ze in 1768 gekocht door de marine voor een wetenschappelijke missie naar de Stille Oceaan en het verkennen van het veronderstelde Terra Australis Incognita of het onbekende Zuid-land. Hernoemd als His Majesty's Bark Endeavour, vertrok het schip uit Plymouth in augustus 1768, voer rond Kaap Hoorn en bereikte Tahiti in 1769. Ze ging toen onder zeil naar de grotendeels onbekend oceaan in het zuiden, en stopte bij de Polynesische eilanden Huahine, Bora Bora en Raiatea die Cook zou opeisen voor Groot-Brittannië.









In september 1769 ging ze voor anker in Nieuw-Zeeland, waar 127 jaar eerder Abel Tasman met zijn Heemskerck het eerste Europese schip was dat de eilanden bereikte. In april 1770, werd de Endeavour het eerste zeeschip nabij de oostkust van Australië waar Cook aan wal ging in wat nu bekendstaat als Botany Bay. De Endeavour zeilde toen noordwaarts langs de Australische kust. Ze kon ternauwernood een ramp ontlopen na het aan de grond lopen op het Great Barrier Reef, en daar nam men zeven weken de tijd om reparaties mogelijk te maken aan de romp. Op 10 oktober 1770, zeilde het schip de haven van Batavia in Nederlands-Indië binnen voor meer substantiële reparaties, haar bemanning werd tot geheimhouding verplicht over de gebieden die zij hadden ontdekt. Het schip hervatte haar reis naar het westen op 26 december, ging rond Kaap de Goede Hoop op 13 maart 1771, en bereikte de haven van Dover in Engeland op 12 juli, na een reis van bijna drie jaar.

I

La HMS Endeavour, nota anche come HM Bark Endeavour, era una nave oceanografica britannica della Royal Navy che il tenente James Cook comandò tra il 1769 e il 1771 durante il suo primo viaggio di esplorazione in Australia e Nuova Zelanda.

Fu varata nel 1764 come carboniera Earl of Pembroke, e la Marina la acquistò nel 1768 per una missione scientifica nell'Oceano Pacifico e per esplorare i mari del Sud a caccia delle prove dell'esistenza dell'ipotetico continente Terra Australis incognita. La Marina la trasformò in un brigantino a palo, la rinominò e la rimise in servizio come His Majesty's Bark the Endeavour. Con a bordo diversi scienziati salpò quindi da Plymouth nell'agosto del 1768, doppiò Capo Horn e raggiunse Tahiti in tempo per osservare il transito di Venere davanti al sole. Dispiegò quindi le vele verso quella parte dei mari del Sud ancora in gran parte inesplorata, fermandosi presso le isole del Pacifico di Huahine, Bora Bora e Raiatea che Cook rivendicò per la Gran Bretagna. Nel settembre del 1769 ancorò al largo della Nuova Zelanda: era la prima nave europea a raggiungere le isole dopo la Heemskerck di Abel Tasman 127 anni prima.

Quando nel mese di aprile 1770 Cook sbarcò in quella che oggi è nota come Botany Bay, l'Endeavour divenne la prima nave europea a raggiungere la costa est dell'Australia. Il vascello navigò poi verso Nord lungo la costa australiana ed evitò per un soffio un disastroso incagliamento sulla Grande Barriera Corallina ma Cook, per alleggerirla e liberarla, fu costretto a gettare alcuni dei suoi cannoni in mare. Fu quindi spiaggiata sulla terraferma per sette settimane per consentire le prime sommarie riparazioni dello scafo. Ripresa la navigazione, il 10 ottobre 1770 entrò arrancando nel porto di Batavia, l'attuale Giacarta nelle Indie Orientali Olandesi, per le riparazioni più accurate mentre Cook faceva giurare al suo equipaggio di mantenere il più stretto riserbo sulle terre che avevano scoperto ed esplorato. Riprese finalmente il suo viaggio verso ovest il 26 dicembre, doppiò il Capo di Buona Speranza il 13 marzo 1771 e raggiunse il porto inglese di Dover il 12 luglio. Era stata in mare per quasi tre anni.

Symboler		=	Farvenummer		=	Colour No.		=	Farben Nr.
Symboles		=	Couleur no.		=	Kleur Nr.		=	Color Nr.
Segno		=	Colore N°		=	Cõr n°			

Til denne model er mahogni bejdse og farver med følgende numre nødvendige:

For this model is mahogany stain and colours with the following numbers should be used:

Für dieses Modell sind Mahagoni Beize und Farben mit den folgenden Nummern notwendig:

Pour ce modèle, le mordant et les couleurs avec les numéros suivants doivent être employées:

Voor dit model zijn kleuren met de volgende nummers nodig:

Para est modelo se necesitan mordiente et colores con los siguientes números:

Per questo modello occorrono inchiostro tinteggiatore "mogano" e colori con questi numeri:

Pinte o modelo com tintura cõr Mogno e as cõres sugeridas da Billing Boats:

Billing	5	=	Tan
Billing	13	=	Trainer Yellow
Billing	14	=	Matt White
Billing	17	=	Gloss Clear Coat
Billing	22	=	Matt Black
Billing	35	=	Signal Red
Billing	36	=	Bejdse/Stain/Beize/Mordant/Beize/Mordient
Billing	38	=	Cobalt Blue

Table contents for "HMS Endeavour" Art. No. 514

Pcs.	No.	Dimension	Material	DK	GB	D	F
1	1	4mm x-veneér	3316L	Køl	Keel	Kiel	Quille
1	2	4mm x-veneér	3316L	Køl	Keel	Kiel	Quille
1	3	4mm x-veneér	3316L	Køl	Keel	Kiel	Quille
1	4	4mm x-veneér	3315L	Spant	Frame	Spant	Couple
1	5	4mm x-veneér	3315L	Spant	Frame	Spant	Couple
1	6	4mm x-veneér	3314L	Spant	Frame	Spant	Couple
1	7	4mm x-veneér	3314L	Spant	Frame	Spant	Couple
1	8	4mm x-veneér	3313L	Spant	Frame	Spant	Couple
1	9	4mm x-veneér	3313L	Spant	Frame	Spant	Couple
1	10	4mm x-veneér	3314L	Spant	Frame	Spant	Couple
1	11	4mm x-veneér	3313L	Spant	Frame	Spant	Couple
1	12	4mm x-veneér	3316L	Spant	Frame	Spant	Couple
1	13	4mm x-veneér	3315L	Spant	Frame	Spant	Couple
1	14	4mm x-veneér	3316L	Spant	Frame	Spant	Couple
1	15	4mm x-veneér	3315L	Spant	Frame	Spant	Couple
1	16	4mm x-veneér	3315L	Hjælpeestykke	Auxiliary piece	Hilfsstücke	Pièce annexes
1	17	4mm x-veneér	3315L	Hjælpeestykke	Auxiliary piece	Hilfsstücke	Pièce annexes
1	18	4mm x-veneér	3315L	Hjælpeestykke	Auxiliary piece	Hilfsstücke	Pièce annexes
1	19	4mm x-veneér	3315L	Hjælpeestykke	Auxiliary piece	Hilfsstücke	Pièce annexes
1	20	4mm x-veneér	3315L	Hjælpeestykke	Auxiliary piece	Hilfsstücke	Pièce annexes
1	21	2mm x-veneér	3318L	Dæk	Deck	Deck	Pont
1	22	2mm x-veneér	3319L	Dæk	Deck	Deck	Pont
1	23	2mm x-veneér	3318L	Dæk	Deck	Deck	Pont
2	24	4mm x-veneér	3314L	Hjælpeestykke	Auxiliary piece	Hilfsstücke	Pièce annexes
2	25	4mm x-veneér	3313L	Hjælpeestykke	Auxiliary piece	Hilfsstücke	Pièce annexes
2	26	4mm x-veneér	3313L	Hjælpeestykke	Auxiliary piece	Hilfsstücke	Pièce annexes
2	27	3mm x-veneér	3317L	Hjælpeestykke	Auxiliary piece	Hilfsstücke	Pièce annexes
1	28	1mm x-veneér	3321L	Galleri	Gallery	Galerie	Galerie
1	29	1mm x-veneér	3321L	Galleri	Gallery	Galerie	Galerie
1	30	2mm x-veneér	3318L	Skot	Bulkhead	Scott	Cloison
1	31	2mm x-veneér	3318L	Skot	Bulkhead	Scott	Cloison
2	32	2mm x-veneér	3318L	Røstbrædt	Chainboard	Rüstbrett	Cadènes de grand mat
2	33	2mm x-veneér	3319L	Røstbrædt	Chainboard	Rüstbrett	Cadènes de grand mat
2	34	2mm x-veneér	3318L	Røstbrædt	Chainboard	Rüstbrett	Cadènes de grand mat

1	35	3mm x-veneér	3317L	Forstærkning	Strenghtening	Verstärkung	Renfort
2	36	5mm x-veneér	3312L	Kranbjælke	Crane former	Kranbalken	Traverses de Grue
6	37	2mm x-veneér	3320L	Støtte	Support	Stütze	Support
12	38	2mm x-veneér	3320L	Pullert	Bollard	Poller	Bitte d'amarrage
8	39	2mm x-veneér	3320L	Rælingsstøtter	Rail stanchions	Relingsstützen	Chandeliers
1	40	3mm x-veneér	3317L	Nedgang	Companion	Niedergang	Couiroir
1	41	3mm x-veneér	3317L	Nedgang	Companion	Niedergang	Couiroir
1	42	1mm x-veneér	3321L	Galleri	Gallery	Galerie	Galerie
1	43	2mm x-veneér	3320L	Galleri, Forstærkning	Gallery, Strenghtening	Galerie, Verstärkung	Galerie, Renfort
2	44	2mm x-veneér	3320L	Beklædningsliste	Plankingstrips	Beplankung	Baguettes de bordé
2	45	2mm x-veneér	3320L	Beklædningsliste	Plankingstrips	Beplankung	Baguettes de bordé
1	46	4mm x-veneér	3316L	Spant	Frame	Spant	Couple
1	47	4mm x-veneér	3314L	Kofilnaglebænk	Belaying pin bench	Belegnägelbank	Ratelier de cordage
1	48	4mm x-veneér	3316L	Kofilnaglebænk	Belaying pin bench	Belegnägelbank	Ratelier de cordage
8	49	4mm x-veneér	3313L	Stolpe	Posts	Stütze	Socle
2	50	4mm x-veneér	3316L	Ankerspil	Anchor winch	Ankerspill	Treuil d'ancre
3	51	1mm x-veneér	3321L	Ankerspil	Anchor winch	Ankerspill	Treuil d'ancre
3	52	1mm x-veneér	3321L	Ankerspil	Anchor winch	Ankerspill	Treuil d'ancre
1	53	3mm x-veneér	3317L	Ankerspil	Anchor winch	Ankerspill	Treuil d'ancre
2	54	4mm x-veneér	3316L	Klokkeårn	Belfry	Glockenturm	Clocher
1	55	4mm x-veneér	3316L	Klokkeårn	Belfry	Glockenturm	Clocher
1	56	2mm x-veneér	3318L	Klokkeårn	Belfry	Glockenturm	Clocher
2	57	2mm x-veneér	3319L	Klokkeårn	Belfry	Glockenturm	Clocher
1	58	4mm x-veneér	3313L	Klokkeårn	Belfry	Glockenturm	Clocher
1	59	1mm x-veneér	3321L	Klokkeårn	Belfry	Glockenturm	Clocher
2	60	2mm x-veneér	3319L	Kofilnaglebænk	Belaying pin bench	Belegnägelbank	Ratelier de cordage
2	61	3mm x-veneér	3317L	Ratsøjle	Wheel column	Steuersäule	Colonne de Roue
2	62	2mm x-veneér	3319L	Ratsøjle	Wheel column	Steuersäule	Colonne de Roue
1	63	3mm x-veneér	3317L	Klokkeårn	Belfry	Glockenturm	Clocher
1	64	4mm x-veneér	3315L	Klokkeårn	Belfry	Glockenturm	Clocher
1	65	1mm x-veneér	3321L	Skylight	Skylight	Oberlicht	Claire voie
1	66	1mm x-veneér	3321L	Skylight	Skylight	Oberlicht	Claire voie
2	67	1mm x-veneér	3321L	Skylight	Skylight	Oberlicht	Claire voie
2	68	1mm x-veneér	3321L	Skylight	Skylight	Oberlicht	Claire voie
1	69	3mm x-veneér	3317L	Ristværk	Grating	Grätting	Grillage

1	70	1mm x-veneér	3321L	Ristværk	Grating	Grätning	Grillage
1	71	1mm x-veneér	3321L	Kapstan	Capstan	Kapstan	Cabestan
2	72	2mm x-veneér	3318L	Kapstan	Capstan	Kapstan	Cabestan
1	73	1mm x-veneér	3321L	Kapstan	Capstan	Kapstan	Cabestan
6	74	2mm x-veneér	3320L	Kapstan	Capstan	Kapstan	Cabestan
1	75	1mm x-veneér	3321L	Kapstan	Capstan	Kapstan	Cabestan
1	76	4mm x-veneér	3315L	Hjælpeestykke	Auxiliary piece	Hilfsstücke	Pièce annexes
1	77	3mm x-veneér	3317L	Liste	Strip	Leisten	Baguette
2	78	3mm x-veneér	3317L	Ratsøjle	Wheel column	Steuersäule	Colonne de Roue
2	79	5mm x-veneér	3312L	Forstærkning	Strengthening	Verstärkung	Renfort
20	80	2mm x-veneér	3320L	Pullert	Bollard	Poller	Bitte d'amarrage
14	81	2mm x-veneér	3320L	Rælingsstøtter	Rail stanchions	Relingsstützen	Chandeliers
2	82	4mm x-veneér	3315L	Klyds	Closed chock	Klüsen	Ecubiérs
2	83	2mm x-veneér	3319L	Hjælpeestykke	Auxiliary piece	Hilfsstücke	Pièce annexes
2	84	1mm x-veneér	3321L	Forstærkning	Strengthening	Verstärkung	Renfort
2	85	1mm x-veneér	3321L	Forstærkning	Strengthening	Verstärkung	Renfort
2	86	1mm x-veneér	3321L	Galleri, Side	Gallery, Side	Gallerie, Seiten	Galerie, Côte
2	87	1mm x-veneér	3321L	Galleri, Side	Gallery, Side	Gallerie, Seiten	Galerie, Côte
2	88	1mm x-veneér	3321L	Luge	Hatch	Luke	Ecoutilles
2	89	1mm x-veneér	3321L	Køl	Keel	Kiel	Quille
2	90	1mm x-veneér	3321L	Køl	Keel	Kiel	Quille
2	91	1mm x-veneér	3321L	Køl	Keel	Kiel	Quille
2	92	3mm x-veneér	3317L	Ror	Rudder	Ruder	Gouvernail
2	93	1mm x-veneér	3321L	Trappe	Stairs	Treppe	Escalier
14	94	1mm x-veneér	3321L	Trappe	Stairs	Treppe	Escalier
2	95	1mm x-veneér	3321L	Trappe	Stairs	Treppe	Escalier
1	96	3mm x-veneér	3317L	Nedgang	Companion	Niedergang	Couvoir
1	97	4mm x-veneér	3315L	Dæk	Deck	Deck	Pont
2	98	1mm x-veneér	3321L	Trappe	Stairs	Treppe	Escalier
4	99	1mm x-veneér	3321L	Trappe	Stairs	Treppe	Escalier
1	100	1mm x-veneér	3321L	Rat	Wheel	Steurrad	Roue
1	101	1mm x-veneér	3321L	Rat	Wheel	Steurrad	Roue
2	102	3mm x-veneér	3317L	Rat	Wheel	Steurrad	Roue
8	103	1mm x-veneér	3321L	Luge	Hatch	Luke	Ecoutilles
20	104	1mm x-veneér	3321L	Hængsel	Hinge	Scharnier	Charnière



4	105	5mm x-veneér	3312L	Lænsepumpe	Bilge pump	Lenzpumpe	Pompe de cale
4	106	4mm x-veneér	3316L	Lænsepumpe	Bilge pump	Lenzpumpe	Pompe de cale
8	107	1mm x-veneér	3321L	Lænsepumpe	Bilge pump	Lenzpumpe	Pompe de cale
8	108	1mm x-veneér	3321L	Lænsepumpe	Bilge pump	Lenzpumpe	Pompe de cale
2	109	1mm x-veneér	3321L	Galleri	Gallery	Galerie	Galerie
2	110	1mm x-veneér	3321L	Galleri	Gallery	Galerie	Galerie
1	111	1mm x-veneér	3321L	Galleri	Gallery	Galerie	Galerie
2	112	1mm x-veneér	3321L	Galleri	Gallery	Galerie	Galerie
2	113	2mm x-veneér	3318L	Ræling	Rail	Reling	Plat bord
2	114	2mm x-veneér	3318L	Ræling	Rail	Reling	Plat bord
1	115	1mm x-veneér	3321L	Lanterne	Light	Laterne	Lanterne
2	116	3mm x-veneér	3317L	Mærs	Top	Mars	Hune
1	117	2mm x-veneér	3320L	Mærs	Top	Mars	Hune
2	118	3mm x-veneér	3317L	Mærs	Top	Mars	Hune
1	119	1mm x-veneér	3321L	Mærs	Top	Mars	Hune
1	120	5mm x-veneér	3312L	Mastbeslag	Mast fittings	Mastbeschlag	Garniture de mât
2	121	3mm x-veneér	3317L	Mærs	Top	Mars	Hune
1	122	2mm x-veneér	3320L	Mærs	Top	Mars	Hune
2	123	3mm x-veneér	3317L	Mærs	Top	Mars	Hune
1	124	1mm x-veneér	3321L	Mærs	Top	Mars	Hune
1	125	5mm x-veneér	3312L	Mastbeslag	Mast fittings	Mastbeschlag	Garniture de mât
2	126	3mm x-veneér	3317L	Mærs	Top	Mars	Hune
1	127	2mm x-veneér	3320L	Mærs	Top	Mars	Hune
2	128	3mm x-veneér	3317L	Mærs	Top	Mars	Hune
1	129	1mm x-veneér	3321L	Mærs	Top	Mars	Hune
1	130	4mm x-veneér	3316L	Mastbeslag	Mast fittings	Mastbeschlag	Garniture de mât
1	131	5mm x-veneér	3312L	Mastbeslag	Mast fittings	Mastbeschlag	Garniture de mât
1	132	5mm x-veneér	3312L	Mastbeslag	Mast fittings	Mastbeschlag	Garniture de mât
1	133	2mm x-veneér	3320L	Mærs	Top	Mars	Hune
1	134	2mm x-veneér	3320L	Mærs	Top	Mars	Hune
1	135	4mm x-veneér	3316L	Mastbeslag	Mast fittings	Mastbeschlag	Garniture de mât
2	136	2mm x-veneér	3320L	Mærs	Top	Mars	Hune
2	137	2mm x-veneér	3320L	Mærs	Top	Mars	Hune
2	138	2mm x-veneér	3320L	Mærs	Top	Mars	Hune
8	139	3mm x-veneér	3317L	Blok	Block	Block	Poulie

2	140	4mm x-veneér	3316L	Støttespant	Support frame	Hilfspant	Pièce d'appui
1	141	1mm x-veneér	3321L	Lanterne	Light	Laterne	Lanterne
1	142	3mm x-veneér	3317L	Bomgaffel	Boom fork	Boom Gabel	Fourche Boom
2	143	3mm x-veneér	3317L	Anker	Anchor	Anker	Ancre
4	144	1mm x-veneér	3321L	Anker	Anchor	Anker	Ancre
2	145	3mm x-veneér	3317L	Anker	Anchor	Anker	Ancre
2	146	4mm x-veneér	3315L	Anker	Anchor	Anker	Ancre
2	147	2mm x-veneér	3320L	Ankerspil	Anchor winch	Ankerspill	Treuil d'ancre
4	148	1mm x-veneér	3321L	Ankerspil	Anchor winch	Ankerspill	Treuil d'ancre
2	149	3mm x-veneér	3317L	Pullert	Bollard	Poller	Bitte d'amarrage
1	150	2mm x-veneér	3320L	Mastfod	Maststep	Mastfuss	Pommes de mat
1	151	2mm x-veneér	3320L	Mastfod	Maststep	Mastfuss	Pommes de mat
1	152	2mm x-veneér	3320L	Mastfod	Maststep	Mastfuss	Pommes de mat
24	153	2mm x-veneér	3320L	Lejder	Ladder	Leiter	Echelle
1	154	2mm x-veneér	3320L	Redningsbåd	Lifeboat	Rettungsboot	Canot de sauvetage
1	155	2mm x-veneér	3320L	Redningsbåd	Lifeboat	Rettungsboot	Canot de sauvetage
10	156	1mm x-veneér	3321L	Skive	Disk	Scheibe	Disque
1	157	2mm x-veneér	3320L	Redningsbåd	Lifeboat	Rettungsboot	Canot de sauvetage
1	158	2mm x-veneér	3320L	Redningsbåd	Lifeboat	Rettungsboot	Canot de sauvetage
1	159	2mm x-veneér	3320L	Redningsbåd	Lifeboat	Rettungsboot	Canot de sauvetage
1	160	2mm x-veneér	3320L	Redningsbåd	Lifeboat	Rettungsboot	Canot de sauvetage
1	161	2mm x-veneér	3320L	Redningsbåd	Lifeboat	Rettungsboot	Canot de sauvetage
1	162	2mm x-veneér	3320L	Redningsbåd	Lifeboat	Rettungsboot	Canot de sauvetage
1	163	1mm x-veneér	3321L	Redningsbåd	Lifeboat	Rettungsboot	Canot de sauvetage
1	164	2mm x-veneér	3320L	Redningsbåd	Lifeboat	Rettungsboot	Canot de sauvetage
1	165	1mm x-veneér	3321L	Redningsbåd	Lifeboat	Rettungsboot	Canot de sauvetage
2	166	2mm x-veneér	3320L	Redningsbåd	Lifeboat	Rettungsboot	Canot de sauvetage
1	167	3mm x-veneér	3317L	Redningsbåd	Lifeboat	Rettungsboot	Canot de sauvetage
1	168	3mm x-veneér	3317L	Redningsbåd	Lifeboat	Rettungsboot	Canot de sauvetage
4	169	0,7x3x550mm	Annegre	Liste	Strip	Leisten	Baguette
46	170	0,7x4x550mm	Annegre	Liste	Strip	Leisten	Baguette
1	171	0,7x6x550mm	Annegre	Liste	Strip	Leisten	Baguette
1	172	1,5x1,5x550mm	Mahogany	Liste	Strip	Leisten	Baguette
5	173	2x2x550mm	Basswood	Liste	Strip	Leisten	Baguette
3	174	2x4x450mm	Basswood	Liste	Strip	Leisten	Baguette

1	175	2x3x200mm	Basswood	Liste	Strip	Leisten	Baguette
60	176	2x6x750mm	Basswood	Liste	Strip	Leisten	Baguette
2	177	2x7x740mm	Basswood	Liste	Strip	Leisten	Baguette
2	178	2x8x740mm	Basswood	Liste	Strip	Leisten	Baguette
1	179	3x3x200mm	Basswood	Liste	Strip	Leisten	Baguette
1	180	4x4x550mm	Basswood	Liste	Strip	Leisten	Baguette
1	181	5x5x550mm	Basswood	Liste	Strip	Leisten	Baguette
1	182+183	ø2x300mm	Basswood	Rundstok	Round stick	Rundstab	Baguette ronde
2	RR11+RR13	ø2x300mm	Basswood	Rundstok	Round stick	Rundstab	Baguette ronde
2	RR12+RR14	ø2x300mm	Basswood	Rundstok	Round stick	Rundstab	Baguette ronde
1	RR7+BM1	ø3x380mm	Basswood	Rundstok	Round stick	Rundstab	Baguette ronde
1	RR8+MS8	ø3x380mm	Basswood	Rundstok	Round stick	Rundstab	Baguette ronde
1	RR9+RR10	ø3x380mm	Basswood	Rundstok	Round stick	Rundstab	Baguette ronde
1	MS9	ø3x155mm	Basswood	Rundstok	Round stick	Rundstab	Baguette ronde
5	RR3+RR4+RR5+RR6+MS10	ø4x260mm	Basswood	Rundstok	Round stick	Rundstab	Baguette ronde
1	MS7+AS1+KS1	ø4x400mm	Basswood	Rundstok	Round stick	Rundstab	Baguette ronde
2	RR1+RR2	ø5x280mm	Basswood	Rundstok	Round stick	Rundstab	Baguette ronde
1	MS5+MS6	ø6x440mm	Basswood	Rundstok	Round stick	Rundstab	Baguette ronde
1	MS3+MS4+SK1	ø8x550mm	Pine	Rundstok	Round stick	Rundstab	Baguette ronde
1	MS2	ø8x290mm	Pine	Rundstok	Round stick	Rundstab	Baguette ronde
1	MS1	ø10x300mm	Pine	Rundstok	Round stick	Rundstab	Baguette ronde
1	184	5mm x-veneér	3312L	Bedding	Slip	Ständer	Cale
1	185	5mm x-veneér	3312L	Bedding	Slip	Ständer	Cale
1	186	5mm x-veneér	3312L	Bedding	Slip	Ständer	Cale
1	187	5mm x-veneér	3312L	Bedding	Slip	Ständer	Cale
1	F 22a	ø0,5x2500mm	Copper	Kobbertråd	Copperthread	Kupferdraht	Fils de cuivre
1	F 39-10	ø1x100mm	Brass	Messingtråd	Brasswire	Messingdraht	Fil de laiton
12	F 54	ø2,5x8mm	Wood	Kofilnagle	Belaying pin	Belegnägel	Cabillots
1	F 56	ø5x5,5mm	Brass	Klokke	Bell	Glocke	Cloche
1	F 70	0,3mm x30m		Rigningstråd	Rigging thread	Takelgarn	Fil de gréement
1	F 71	0,5mm x50m		Rigningstråd	Rigging thread	Takelgarn	Fil de gréement
1	F 72	0,8mm x20m		Rigningstråd	Rigging thread	Takelgarn	Fil de gréement
1	F 73	1,2mm x4m		Rigningstråd	Rigging thread	Takelgarn	Fil de gréement
1	F 74	2mm x2m		Rigningstråd	Rigging thread	Takelgarn	Fil de gréement
1	F 120-2	ø14x10mm	Plastic	Lanterne	Light	Laternen	Feux de navigation

1	F 120-3	ø10x8mm	Plastic	Lanterne	Light	Laternen	Feux de navigation
1	F 120-4	ø2x45mm	Brass	Messingtråd	Brasswire	Messingdraht	Fil de laiton
6	F 163	ø6x40mm	Brass	Kanon	Canon	Kanon	Canon
6	F 164, 1-8	2mm x-veneér	F 164L-4	Lavet	Carriage	Lafette	Affut de canon
8	F 230	0,7x7mm	Brass	Søm	Pins	Nägel	Clous
1	F 327	25cm	Brass	Kæde	Chain	Kette	Chaîne
10	F 348	4x9mm	Plastic	Klampe	Cleats	Klampen	Taquets
6	F 404	ø1,2x13mm	Brass	Søm	Pins	Nägel	Clous
1	F 409-10	ø1,5x100mm	Brass	Messingtråd	Brasswire	Messingdraht	Fil de laiton
1	F 409	ø1,5x250mm	Brass	Messingtråd	Brasswire	Messingdraht	Fil de laiton
1	F 464	ø8x5mm	Brass	Lanterne	Light	Laternen	Feux de navigation
10	F 495	ø4x24mm	Brass	Kanon	Canon	Kanon	Canon
60	F 537	0,5x2,2x25mm	Brass	Røstjern	Chain plates	Rüsteisen	Cadènes
7	F 624	0,4x2,5x140mm	Brass	Bånd	Tape	Band	Bande
2	F 663	ø0,8x250mm	Brass	Messingtråd	Brasswire	Messingdraht	Fil de laiton
60	F 664	0,5x11mm	Brass	Øjebolt	Eye bolt	Augenbolzen	Pitons
68	F 695	ø5x2mm	Wood	Jomfru	Dead eye	Jungfern	Cap de mouton
56	F 696	ø7x3mm	Wood	Jomfru	Dead eye	Jungfern	Cap de mouton
15	F 697	4x5mm	Wood	Enkelt blok	Single blocks	Einzel, block	Poulies simple
2	F 698	5x5mm	Wood	Dobbelt blok	Double blocks	Doppel, block	Poulies doubles
3	F 743	0,7x13mm	Brass	Øjebolt	Eye bolt	Augenbolzen	Pitons
54	F 767	3x4mm	Wood	Enkelt blok	Single blocks	Einzel, block	Poulies simple
16	F 922	ø3x2mm	Brass	Ring	Ring	Ring	Anneau
1	F 930	Ø6x35mm	Brass	Messingrør	Brass pipes	Messingrohr	Tuyaux en laiton
6	F 1006	ø8x11mm	Wood	Tønde	Barrel	Fass	Baril
1	F 1007	ø30x4,5mm	Brass	Rat	Wheel	Steurrad	Roue
1		80x50mm	Acetate	Vinduer	Windows	Fenster	Fenêtres
1	FL 153			Flag	Flag	Flagge	Drapeau
1		A4		Byggevejledning	Building instruction	Bauanleitung	Instruction de montage
1		A3		Byggevejledning/mast	Building instruction/masts	Bauanleitung/mast	Instruction de montage/Mât
1	50-50105			Hovedtegning Plan 1	Maindrawing 1	Zeichnung 1	Plan 1
1		96201		Sejl	Sail	Segel	Voil
1		96202		Sejl	Sail	Segel	Voil

Table contents for "HMS Endeavour" Art. No. 514

Pcs.	No.	Dimension	Material	NL	E	I	P
1	1	4mm x-veneér	3316L	Kiel	Quilla	Chiglia	Quilha
1	2	4mm x-veneér	3316L	Kiel	Quilla	Chiglia	Quilha
1	3	4mm x-veneér	3316L	Kiel	Quilla	Chiglia	Quilha
1	4	4mm x-veneér	3315L	Spant	Cuaderna	Ordinata	Armacao
1	5	4mm x-veneér	3315L	Spant	Cuaderna	Ordinata	Armacao
1	6	4mm x-veneér	3314L	Spant	Cuaderna	Ordinata	Armacao
1	7	4mm x-veneér	3314L	Spant	Cuaderna	Ordinata	Armacao
1	8	4mm x-veneér	3313L	Spant	Cuaderna	Ordinata	Armacao
1	9	4mm x-veneér	3313L	Spant	Cuaderna	Ordinata	Armacao
1	10	4mm x-veneér	3314L	Spant	Cuaderna	Ordinata	Armacao
1	11	4mm x-veneér	3313L	Spant	Cuaderna	Ordinata	Armacao
1	12	4mm x-veneér	3316L	Spant	Cuaderna	Ordinata	Armacao
1	13	4mm x-veneér	3315L	Spant	Cuaderna	Ordinata	Armacao
1	14	4mm x-veneér	3316L	Spant	Cuaderna	Ordinata	Armacao
1	15	4mm x-veneér	3315L	Spant	Cuaderna	Ordinata	Armacao
1	16	4mm x-veneér	3315L	Vulstukken	Trozo de ayuda	Pezzo ausiliario	Peças auxiliares
1	17	4mm x-veneér	3315L	Vulstukken	Trozo de ayuda	Pezzo ausiliario	Peças auxiliares
1	18	4mm x-veneér	3315L	Vulstukken	Trozo de ayuda	Pezzo ausiliario	Peças auxiliares
1	19	4mm x-veneér	3315L	Vulstukken	Trozo de ayuda	Pezzo ausiliario	Peças auxiliares
1	20	4mm x-veneér	3315L	Vulstukken	Trozo de ayuda	Pezzo ausiliario	Peças auxiliares
1	21	2mm x-veneér	3318L	Dek	Cubierta	Ponte	Convés
1	22	2mm x-veneér	3319L	Dek	Cubierta	Ponte	Convés
1	23	2mm x-veneér	3318L	Dek	Cubierta	Ponte	Convés
2	24	4mm x-veneér	3314L	Vulstukken	Trozo de ayuda	Pezzo ausiliario	Peças auxiliares
2	25	4mm x-veneér	3313L	Vulstukken	Trozo de ayuda	Pezzo ausiliario	Peças auxiliares
2	26	4mm x-veneér	3313L	Vulstukken	Trozo de ayuda	Pezzo ausiliario	Peças auxiliares
2	27	3mm x-veneér	3317L	Vulstukken	Trozo de ayuda	Pezzo ausiliario	Peças auxiliares
1	28	1mm x-veneér	3321L	Galerie	Galeria	Galleria	Galeria
1	29	1mm x-veneér	3321L	Galerie	Galeria	Galleria	Galeria
1	30	2mm x-veneér	3318L	Schot	Camarote	Paratia	Intermediária
1	31	2mm x-veneér	3318L	Schot	Camarote	Paratia	Intermediária
2	32	2mm x-veneér	3318L	Rusten	Cadenote	Asse di catene	Correntes do Mastro Principal
2	33	2mm x-veneér	3319L	Rusten	Cadenote	Asse di catene	Correntes do Mastro Principal

2	34	2mm x-veneér	3318L	Rusten	Cadenote	Asse di catene	Correntes do Mastro Principal
1	35	3mm x-veneér	3317L	Versterkenen	Refuerzo	Rinforzo	Reforço
2	36	5mm x-veneér	3312L	Kraan Spantdelen	Tablón de grúa	Trave della gru	Guindaste
6	37	2mm x-veneér	3320L	Steun	Soporto	Supporto	Suporte
12	38	2mm x-veneér	3320L	Bolder	Bitón	Bitta	Abita
8	39	2mm x-veneér	3320L	Railingspalen	Soporte de pasamanos	Supporti per corrimano	Pontaletes da amurada
1	40	3mm x-veneér	3317L	Trapafgang	Bajada	Scaletta di boccaporto	Escotilha de descida
1	41	3mm x-veneér	3317L	Trapafgang	Bajada	Scaletta di boccaporto	Escotilha de descida
1	42	1mm x-veneér	3321L	Galerie	Galeria	Galleria	Galeria
1	43	2mm x-veneér	3320L	Galerie, Versterkenen	Galeria, Refuerzo	Galleria, Rinforzo	Galeria, Reforço
2	44	2mm x-veneér	3320L	Rompbekleding	Listónes de forro	Listelli fasciame	Tiras
2	45	2mm x-veneér	3320L	Rompbekleding	Listónes de forro	Listelli fasciame	Tiras
1	46	4mm x-veneér	3316L	Spant	Cuaderna	Ordinata	Armacao
1	47	4mm x-veneér	3314L	Nagelbank	Caballetes	Cavaletto	Assento de amarração
1	48	4mm x-veneér	3316L	Nagelbank	Caballetes	Cavaletto	Assento de amarração
8	49	4mm x-veneér	3313L	Paal	Poste	Supporto	Poste
2	50	4mm x-veneér	3316L	Ankerwinch	Chigre de ancla	Argano dell'ancora	Guincho da âncora
3	51	1mm x-veneér	3321L	Ankerwinch	Chigre de ancla	Argano dell'ancora	Guincho da âncora
3	52	1mm x-veneér	3321L	Ankerwinch	Chigre de ancla	Argano dell'ancora	Guincho da âncora
1	53	3mm x-veneér	3317L	Ankerwinch	Chigre de ancla	Argano dell'ancora	Guincho da âncora
2	54	4mm x-veneér	3316L	Klokkentoren	Campanario	Campanile	Campanário
1	55	4mm x-veneér	3316L	Klokkentoren	Campanario	Campanile	Campanário
1	56	2mm x-veneér	3318L	Klokkentoren	Campanario	Campanile	Campanário
2	57	2mm x-veneér	3319L	Klokkentoren	Campanario	Campanile	Campanário
1	58	4mm x-veneér	3313L	Klokkentoren	Campanario	Campanile	Campanário
1	59	1mm x-veneér	3321L	Klokkentoren	Campanario	Campanile	Campanário
2	60	2mm x-veneér	3319L	Nagelbank	Caballetes	Cavaletto	Assento de amarração
2	61	3mm x-veneér	3317L	Stuurwiel zuil	Columna de volante	Supporto ruota	Suporte do timão
2	62	2mm x-veneér	3319L	Stuurwiel zuil	Columna de volante	Supporto ruota	Suporte do timão
1	63	3mm x-veneér	3317L	Klokkentoren	Campanario	Campanile	Campanário
1	64	4mm x-veneér	3315L	Klokkentoren	Campanario	Campanile	Campanário
1	65	1mm x-veneér	3321L	Bovenlicht	Lumbrera	Osteriggio	Clarabóia
1	66	1mm x-veneér	3321L	Bovenlicht	Lumbrera	Osteriggio	Clarabóia
2	67	1mm x-veneér	3321L	Bovenlicht	Lumbrera	Osteriggio	Clarabóia
2	68	1mm x-veneér	3321L	Bovenlicht	Lumbrera	Osteriggio	Clarabóia

1	69	3mm x-veneér	3317L	Roosterwerk	Emparillado	Piattaforma di poppa	Grade
1	70	1mm x-veneér	3321L	Roosterwerk	Emparillado	Piattaforma di poppa	Grade
1	71	1mm x-veneér	3321L	Gangspil	Cabrestante	Argano	Cabrestante
2	72	2mm x-veneér	3318L	Gangspil	Cabrestante	Argano	Cabrestante
1	73	1mm x-veneér	3321L	Gangspil	Cabrestante	Argano	Cabrestante
6	74	2mm x-veneér	3320L	Gangspil	Cabrestante	Argano	Cabrestante
1	75	1mm x-veneér	3321L	Gangspil	Cabrestante	Argano	Cabrestante
1	76	4mm x-veneér	3315L	Vulstukken	Trozo de ayuda	Pezzo ausiliario	Peças auxiliares
1	77	3mm x-veneér	3317L	Strip	Listón	Listello	Tira
2	78	3mm x-veneér	3317L	Stuurwiel zuil	Columna de volante	Supporto ruota	Suporte do timão
2	79	5mm x-veneér	3312L	Versterkenen	Refuerzo	Rinforzo	Reforço
20	80	2mm x-veneér	3320L	Bolder	Bitón	Bitta	Abita
14	81	2mm x-veneér	3320L	Railingspalen	Soporte de pasamanos	Supporti per corrimano	Pontaletes da amurada
2	82	4mm x-veneér	3315L	Verhaalklampen	Bocina	Passacavi	Escovéns
2	83	2mm x-veneér	3319L	Vulstukken	Trozo de ayuda	Pezzo ausiliario	Peças auxiliares
2	84	1mm x-veneér	3321L	Versterkenen	Refuerzo	Rinforzo	Reforço
2	85	1mm x-veneér	3321L	Versterkenen	Refuerzo	Rinforzo	Reforço
2	86	1mm x-veneér	3321L	Galerie, Kant	Galería, Lateral	Galleria, Fiancate	Galeria, Lateral
2	87	1mm x-veneér	3321L	Galerie, Kant	Galería, Lateral	Galleria, Fiancate	Galeria, Lateral
2	88	1mm x-veneér	3321L	Luikdeel	Escotilla	Boccaporto	Escotilha
2	89	1mm x-veneér	3321L	Kiel	Quilla	Chiglia	Quilha
2	90	1mm x-veneér	3321L	Kiel	Quilla	Chiglia	Quilha
2	91	1mm x-veneér	3321L	Kiel	Quilla	Chiglia	Quilha
2	92	3mm x-veneér	3317L	Roer	Timón	Timone	Leme
2	93	1mm x-veneér	3321L	Trap	Escalera	Scaletta	Degraus
14	94	1mm x-veneér	3321L	Trap	Escalera	Scaletta	Degraus
2	95	1mm x-veneér	3321L	Trap	Escalera	Scaletta	Degraus
1	96	3mm x-veneér	3317L	Trapafgang	Bajada	Scaletta di boccaporto	Escotilha de descida
1	97	4mm x-veneér	3315L	Dek	Cubierta	Ponte	Convés
2	98	1mm x-veneér	3321L	Trap	Escalera	Scaletta	Degraus
4	99	1mm x-veneér	3321L	Trap	Escalera	Scaletta	Degraus
1	100	1mm x-veneér	3321L	Stuurwiel	Volante	Ruota del timone	Volante do timão
1	101	1mm x-veneér	3321L	Stuurwiel	Volante	Ruota del timone	Volante do timão
2	102	3mm x-veneér	3317L	Stuurwiel	Volante	Ruota del timone	Volante do timão
8	103	1mm x-veneér	3321L	Luikdeel	Escotilla	Boccaporto	Escotilha

20	104	1mm x-veneér	3321L	Hengsel	Charnela	Cerniera	Dobradiça
4	105	5mm x-veneér	3312L	Lenspomp	Bomba de achique	Pompa di sentina	Bomba de porão
4	106	4mm x-veneér	3316L	Lenspomp	Bomba de achique	Pompa di sentina	Bomba de porão
8	107	1mm x-veneér	3321L	Lenspomp	Bomba de achique	Pompa di sentina	Bomba de porão
8	108	1mm x-veneér	3321L	Lenspomp	Bomba de achique	Pompa di sentina	Bomba de porão
2	109	1mm x-veneér	3321L	Galerie	Galeria	Galleria	Galeria
2	110	1mm x-veneér	3321L	Galerie	Galeria	Galleria	Galeria
1	111	1mm x-veneér	3321L	Galerie	Galeria	Galleria	Galeria
2	112	1mm x-veneér	3321L	Galerie	Galeria	Galleria	Galeria
2	113	2mm x-veneér	3318L	Reling	Borda	Parapetto	Amurada
2	114	2mm x-veneér	3318L	Reling	Borda	Parapetto	Amurada
1	115	1mm x-veneér	3321L	Boordlichten	Linterna	Lanterna di bordo	Luzes
2	116	3mm x-veneér	3317L	Wangen	Verga	Coffa	Topo
1	117	2mm x-veneér	3320L	Wangen	Verga	Coffa	Topo
2	118	3mm x-veneér	3317L	Wangen	Verga	Coffa	Topo
1	119	1mm x-veneér	3321L	Wangen	Verga	Coffa	Topo
1	120	5mm x-veneér	3312L	Mastbeslag	Herrajes de palo	Accessori albero	Braçadeira do mastro
2	121	3mm x-veneér	3317L	Wangen	Verga	Coffa	Topo
1	122	2mm x-veneér	3320L	Wangen	Verga	Coffa	Topo
2	123	3mm x-veneér	3317L	Wangen	Verga	Coffa	Topo
1	124	1mm x-veneér	3321L	Wangen	Verga	Coffa	Topo
1	125	5mm x-veneér	3312L	Mastbeslag	Herrajes de palo	Accessori albero	Braçadeira do mastro
2	126	3mm x-veneér	3317L	Wangen	Verga	Coffa	Topo
1	127	2mm x-veneér	3320L	Wangen	Verga	Coffa	Topo
2	128	3mm x-veneér	3317L	Wangen	Verga	Coffa	Topo
1	129	1mm x-veneér	3321L	Wangen	Verga	Coffa	Topo
1	130	4mm x-veneér	3316L	Mastbeslag	Herrajes de palo	Accessori albero	Braçadeira do mastro
1	131	5mm x-veneér	3312L	Mastbeslag	Herrajes de palo	Accessori albero	Braçadeira do mastro
1	132	5mm x-veneér	3312L	Mastbeslag	Herrajes de palo	Accessori albero	Braçadeira do mastro
1	133	2mm x-veneér	3320L	Wangen	Verga	Coffa	Topo
1	134	2mm x-veneér	3320L	Wangen	Verga	Coffa	Topo
1	135	4mm x-veneér	3316L	Mastbeslag	Herrajes de palo	Accessori albero	Braçadeira do mastro
2	136	2mm x-veneér	3320L	Wangen	Verga	Coffa	Topo
2	137	2mm x-veneér	3320L	Wangen	Verga	Coffa	Topo
2	138	2mm x-veneér	3320L	Wangen	Verga	Coffa	Topo



8	139	3mm x-veneér	3317L	Blok	Polea	Blocchi	Blocos
2	140	4mm x-veneér	3316L	Hulpspanten	Cuaderna de apoyo	Ordinata di supporto	Arracáo de apoio
1	141	1mm x-veneér	3321L	Boordlichten	Linterna	Lanterna di bordo	Luzes
1	142	3mm x-veneér	3317L	Boom vork	Boom tenedor	Boom forchetta	Garfo Boom
2	143	3mm x-veneér	3317L	Anker	Ancla	Ancora	Âncora
4	144	1mm x-veneér	3321L	Anker	Ancla	Ancora	Âncora
2	145	3mm x-veneér	3317L	Anker	Ancla	Ancora	Âncora
2	146	4mm x-veneér	3315L	Anker	Ancla	Ancora	Âncora
2	147	2mm x-veneér	3320L	Ankerwinch	Chigre de ancla	Argano dell'ancora	Guincho da âncora
4	148	1mm x-veneér	3321L	Ankerwinch	Chigre de ancla	Argano dell'ancora	Guincho da âncora
2	149	3mm x-veneér	3317L	Bolder	Bitón	Bitta	Abita
1	150	2mm x-veneér	3320L	Dekdoorvoer mast	Base del palo	Piede d'albero	Degrau do mastro
1	151	2mm x-veneér	3320L	Dekdoorvoer mast	Base del palo	Piede d'albero	Degrau do mastro
1	152	2mm x-veneér	3320L	Dekdoorvoer mast	Base del palo	Piede d'albero	Degrau do mastro
24	153	2mm x-veneér	3320L	Ladder	Escala	Scala	Escada
1	154	2mm x-veneér	3320L	Reddingsboot	Bote salvavida	Scialuppa di salvataggio	Bote salva-vidas
1	155	2mm x-veneér	3320L	Reddingsboot	Bote salvavida	Scialuppa di salvataggio	Bote salva-vidas
10	156	1mm x-veneér	3321L	Disk	Disco	Disco	Disco
1	157	2mm x-veneér	3320L	Reddingsboot	Bote salvavida	Scialuppa di salvataggio	Bote salva-vidas
1	158	2mm x-veneér	3320L	Reddingsboot	Bote salvavida	Scialuppa di salvataggio	Bote salva-vidas
1	159	2mm x-veneér	3320L	Reddingsboot	Bote salvavida	Scialuppa di salvataggio	Bote salva-vidas
1	160	2mm x-veneér	3320L	Reddingsboot	Bote salvavida	Scialuppa di salvataggio	Bote salva-vidas
1	161	2mm x-veneér	3320L	Reddingsboot	Bote salvavida	Scialuppa di salvataggio	Bote salva-vidas
1	162	2mm x-veneér	3320L	Reddingsboot	Bote salvavida	Scialuppa di salvataggio	Bote salva-vidas
1	163	1mm x-veneér	3321L	Reddingsboot	Bote salvavida	Scialuppa di salvataggio	Bote salva-vidas
1	164	2mm x-veneér	3320L	Reddingsboot	Bote salvavida	Scialuppa di salvataggio	Bote salva-vidas
1	165	1mm x-veneér	3321L	Reddingsboot	Bote salvavida	Scialuppa di salvataggio	Bote salva-vidas
2	166	2mm x-veneér	3320L	Reddingsboot	Bote salvavida	Scialuppa di salvataggio	Bote salva-vidas
1	167	3mm x-veneér	3317L	Reddingsboot	Bote salvavida	Scialuppa di salvataggio	Bote salva-vidas
1	168	3mm x-veneér	3317L	Reddingsboot	Bote salvavida	Scialuppa di salvataggio	Bote salva-vidas
4	169	0,7x3x550mm	Annegre	Strip	Listón	Listello	Tira
46	170	0,7x4x550mm	Annegre	Strip	Listón	Listello	Tira
1	171	0,7x6x550mm	Annegre	Strip	Listón	Listello	Tira
1	172	1,5x1,5x550mm	Mahogany	Strip	Listón	Listello	Tira
5	173	2x2x550mm	Basswood	Strip	Listón	Listello	Tira

3	174	2x4x450mm	Basswood	Strip	Listón	Listello	Tira
1	175	2x3x200mm	Basswood	Strip	Listón	Listello	Tira
60	176	2x6x750mm	Basswood	Strip	Listón	Listello	Tira
2	177	2x7x740mm	Basswood	Strip	Listón	Listello	Tira
2	178	2x8x740mm	Basswood	Strip	Listón	Listello	Tira
1	179	3x3x200mm	Basswood	Strip	Listón	Listello	Tira
1	180	4x4x550mm	Basswood	Strip	Listón	Listello	Tira
1	181	5x5x550mm	Basswood	Strip	Listón	Listello	Tira
1	182+183	ø2x300mm	Basswood	Rondhout	Barra reronda	Tondino (listello)	Bastão cilíndrico
2	RR11+RR13	ø2x300mm	Basswood	Rondhout	Barra reronda	Tondino (listello)	Bastão cilíndrico
2	RR12+RR14	ø2x300mm	Basswood	Rondhout	Barra reronda	Tondino (listello)	Bastão cilíndrico
1	RR7+BM1	ø3x380mm	Basswood	Rondhout	Barra reronda	Tondino (listello)	Bastão cilíndrico
1	RR8+MS8	ø3x380mm	Basswood	Rondhout	Barra reronda	Tondino (listello)	Bastão cilíndrico
1	RR9+RR10	ø3x380mm	Basswood	Rondhout	Barra reronda	Tondino (listello)	Bastão cilíndrico
1	MS9	ø3x155mm	Basswood	Rondhout	Barra reronda	Tondino (listello)	Bastão cilíndrico
5	RR3+RR4+RR5+RR6+MS10	ø4x260mm	Basswood	Rondhout	Barra reronda	Tondino (listello)	Bastão cilíndrico
1	MS7+AS1+KS1	ø4x400mm	Basswood	Rondhout	Barra reronda	Tondino (listello)	Bastão cilíndrico
2	RR1+RR2	ø5x280mm	Basswood	Rondhout	Barra reronda	Tondino (listello)	Bastão cilíndrico
1	MS5+MS6	ø6x440mm	Basswood	Rondhout	Barra reronda	Tondino (listello)	Bastão cilíndrico
1	MS3+MS4+SK1	ø8x550mm	Pine	Rondhout	Barra reronda	Tondino (listello)	Bastão cilíndrico
1	MS2	ø8x290mm	Pine	Rondhout	Barra reronda	Tondino (listello)	Bastão cilíndrico
1	MS1	ø10x300mm	Pine	Rondhout	Barra reronda	Tondino (listello)	Bastão cilíndrico
1	184	5mm x-veneér	3312L	Standaard	Grada	Supporto	Pé do suporte
1	185	5mm x-veneér	3312L	Standaard	Grada	Supporto	Pé do suporte
1	186	5mm x-veneér	3312L	Standaard	Grada	Supporto	Pé do suporte
1	187	5mm x-veneér	3312L	Standaard	Grada	Supporto	Pé do suporte
1	F 22a	ø0,5x2500mm	Copper	Koperdraad	Alambre de cobre	Filo in rame	Fio de cobre
1	F 39-10	ø1x100mm	Brass	Messingdraad	Hilo de latón	Filo in ottone	Tubo do guincho
12	F 54	ø2,5x8mm	Wood	Korvijnnagel	Cabillas	Ribattino	Pino de amarração
1	F 56	ø5x5,5mm	Brass	Scheepsbel	Campanilla	Campana	Sino
1	F 70	0,3mm x30m		Takelgaren	Hilo de oparejo	Filo per manovre	Linha de cordame
1	F 71	0,5mm x50m		Takelgaren	Hilo de oparejo	Filo per manovre	Linha de cordame
1	F 72	0,8mm x20m		Takelgaren	Hilo de oparejo	Filo per manovre	Linha de cordame
1	F 73	1,2mm x4m		Takelgaren	Hilo de oparejo	Filo per manovre	Linha de cordame
1	F 74	2mm x2m		Takelgaren	Hilo de oparejo	Filo per manovre	Linha de cordame

1	F 120-2	ø14x10mm	Plastic	Boordlichten	Linternas	Lanterna di bordo	Luzes
1	F 120-3	ø10x8mm	Plastic	Boordlichten	Linternas	Lanterna di bordo	Luzes
1	F 120-4	ø2x45mm	Brass	Messingdraad	Hilo de latón	Filo in ottone	Tubo do guincho
6	F 163	ø6x40mm	Brass	Kanon	Cañon	Cannone	Canhão
6	F 164, 1-8	2mm x-veneér	F 164L-4	Kanonwagen	Cureña	Affusto	Carro
8	F 230	0,7x7mm	Brass	Spijkertjes	Clavos	Chiodi	Pino
1	F 327	25cm	Brass	Ketting	Cadena de ancla	Catena ancora	Corrente da âncora
10	F 348	4x9mm	Plastic	Kikkers	Cornamusas	Gallocce	Castanha ("T" de amarra)
6	F 404	ø1,2x13mm	Brass	Spijkertjes	Clavos	Chiodi	Pino
1	F 409-10	ø1,5x100mm	Brass	Messingdraad	Hilo de latón	Filo in ottone	Tubo do guincho
1	F 409	ø1,5x250mm	Brass	Messingdraad	Hilo de latón	Filo in ottone	Tubo do guincho
1	F 464	ø8x5mm	Brass	Boordlichten	Linternas	Lanterna di bordo	Luzes
10	F 495	ø4x24mm	Brass	Kanon	Cañon	Cannone	Canhão
60	F 537	0,5x2,2x25mm	Brass	Puttings	Cadenote	Landra	Placas das correntes
7	F 624	0,4x2,5x140mm	Brass	Band	Cinta	Nastro	Fita
2	F 663	ø0,8x250mm	Brass	Messingdraad	Hilo de latón	Filo in ottone	Tubo do guincho
60	F 664	0,5x11mm	Brass	Oogbauten	Pernos de cáncamo	Bullone ad occhio	Ferrolho
68	F 695	ø5x2mm	Wood	Jufferblokken	Virgenes	Testa di montone	Bigota
56	F 696	ø7x3mm	Wood	Jufferblokken	Virgenes	Testa di montone	Bigota
15	F 697	4x5mm	Wood	Enkel, blok	Polea, simple	Blocchi (semplici)	Blocos Simples
2	F 698	5x5mm	Wood	Dubbel, blok	Polea, doble	Blocchi (doppi)	Blocos Duplos
3	F 743	0,7x13mm	Brass	Oogbauten	Pernos de cáncamo	Bullone ad occhio	Ferrolho
54	F 767	3x4mm	Wood	Enkel, blok	Polea, simple	Blocchi (semplici)	Blocos Simples
16	F 922	ø3x2mm	Brass	Ring	Anillo	Anello	Anel
1	F 930	Ø6x35mm	Brass	Messingbuis	Tubo de latón	Tubo di ottone	Tubo de latão
6	F 1006	ø8x11mm	Wood	Vat	Barril	Barile	Barril
1	F 1007	ø30x4,5mm	Brass	Stuurwiel	Volante	Buota del timone	Volante do timão
1		80x50mm	Acetate	Raam	Ventanas	Finestrini	Janelas
1	FL 153			Vlag	Bandera	Bandiere	Bandeira
1		A4		Bouwbeschrijving	Instrucciones de construccion	Istruzioni di montaggio	Manual de instruções
1		A3		Bouwbeschrijving/mast	Instrucciones de construccion/palo	Istruzioni di montaggio/albero	Manual de instruções/mastros
1	50-50105			Tekening 1	Ilustración 1	Piani di costruzione 1	Planta principal 1
1		96201		Zeil	Vela	Vela	Vela
1		96202		Zeil	Vela	Vela	Vela

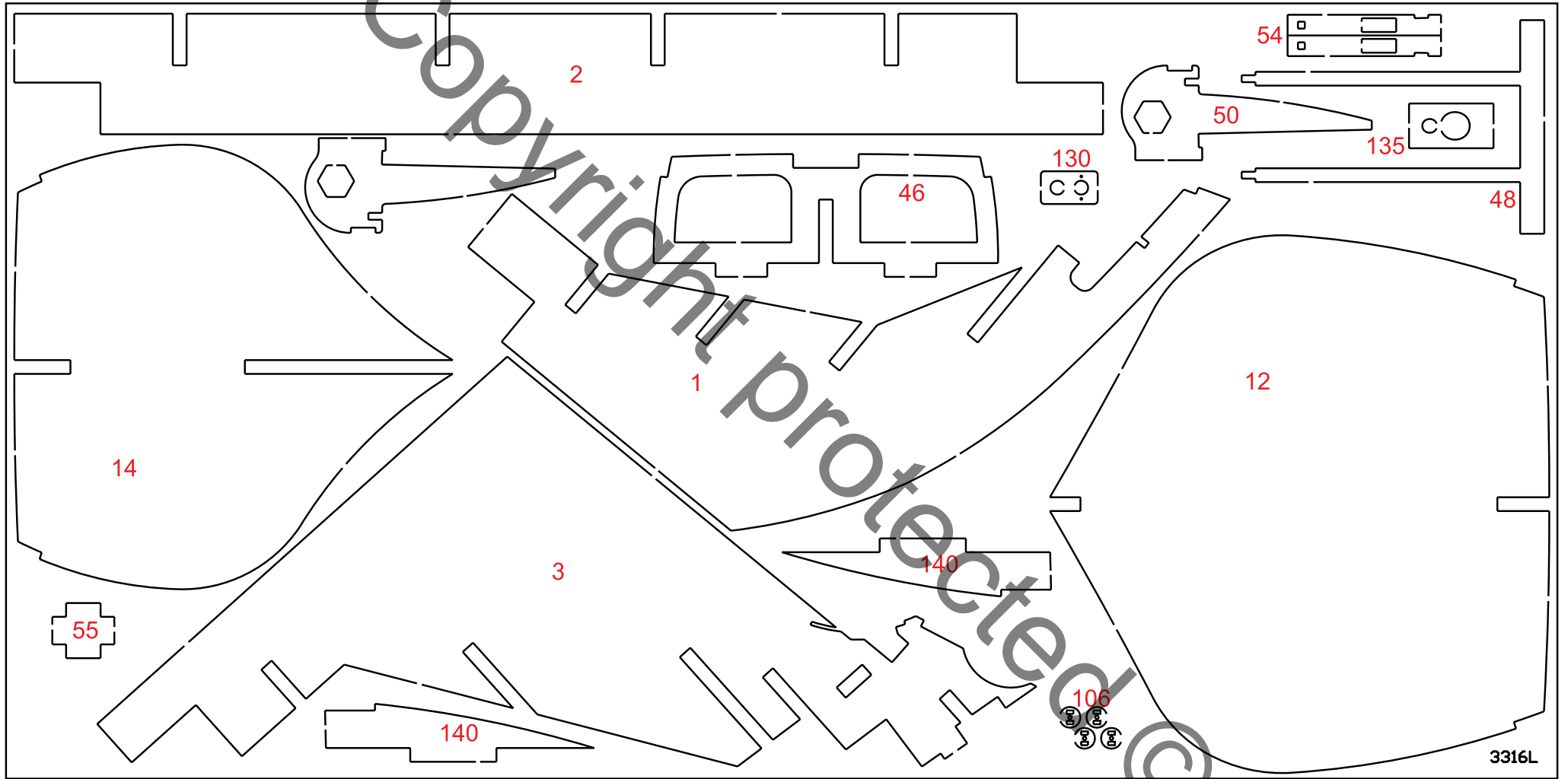

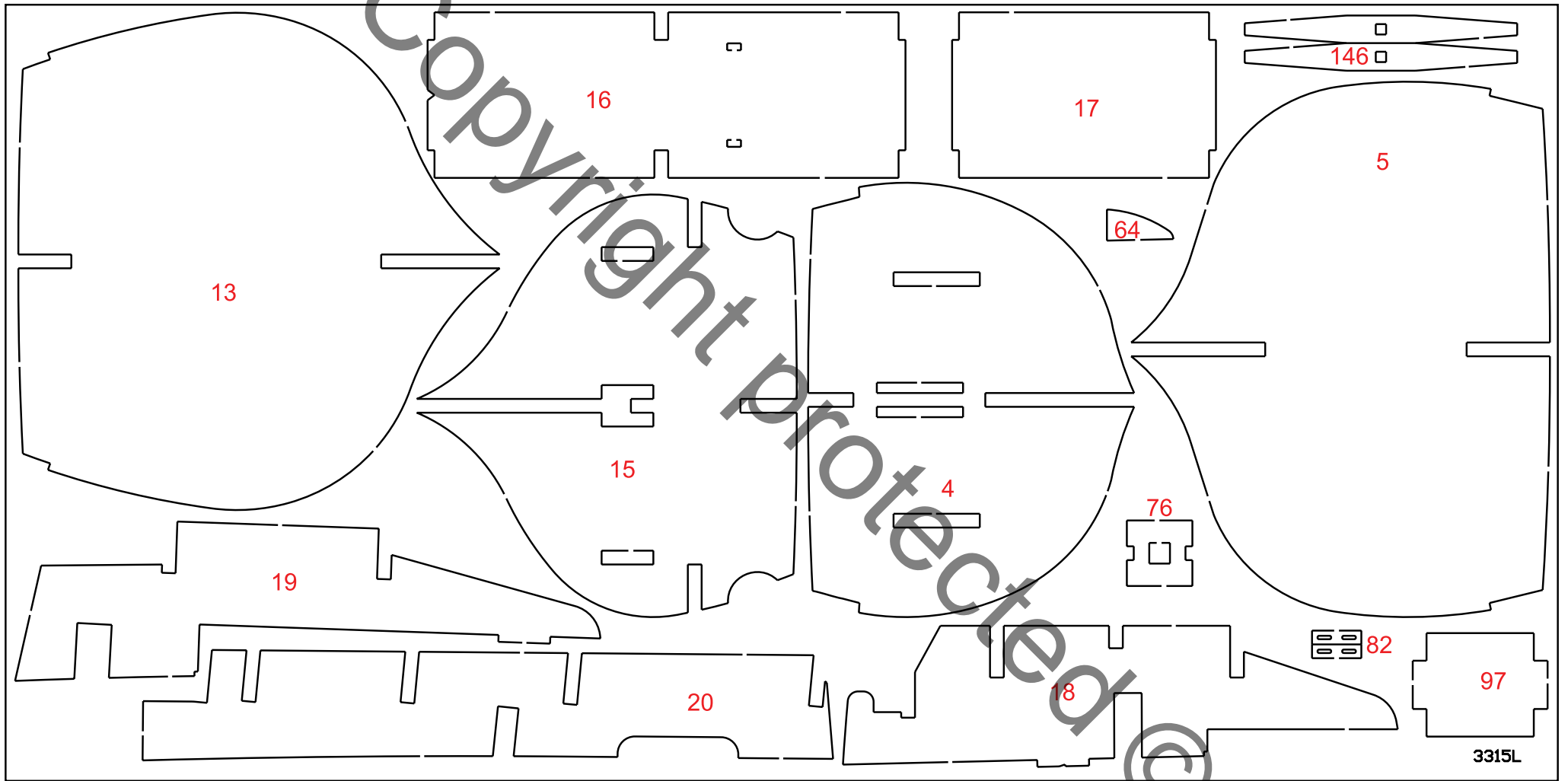

Copyright protected ©

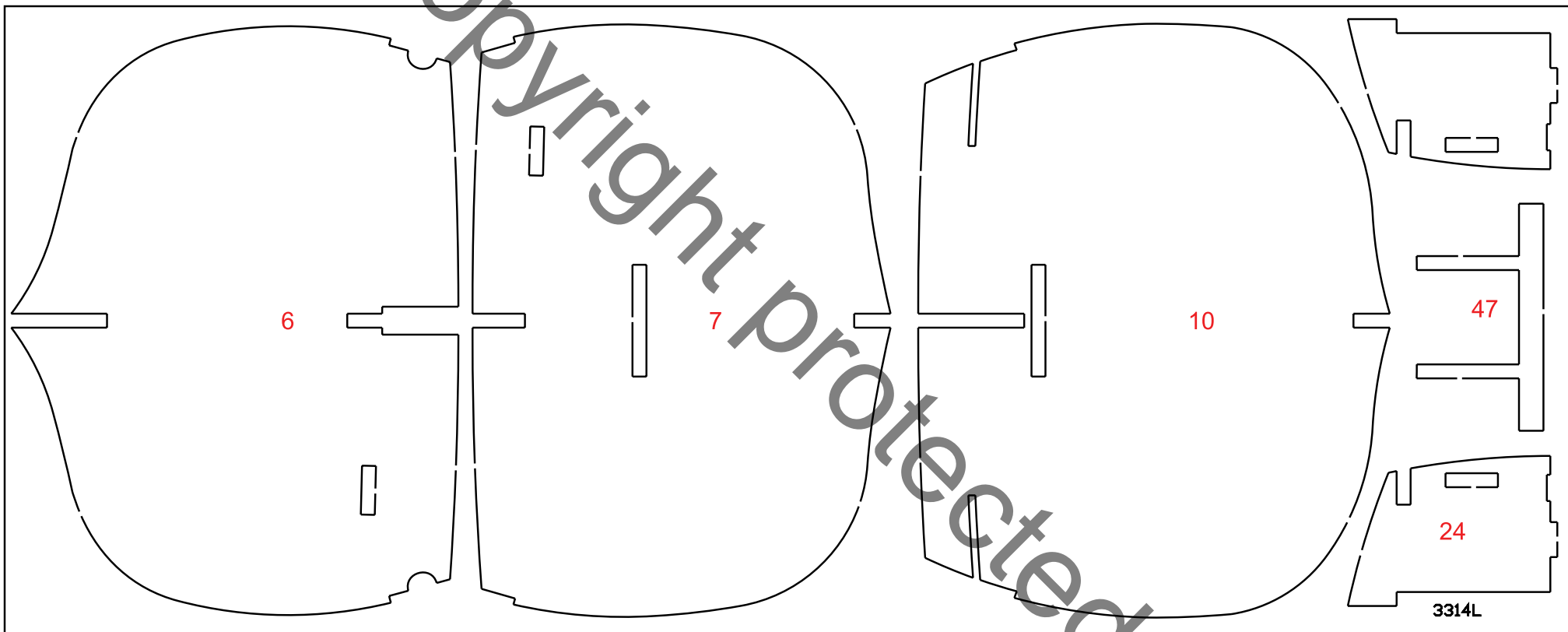

3314L

Copyright protected ©

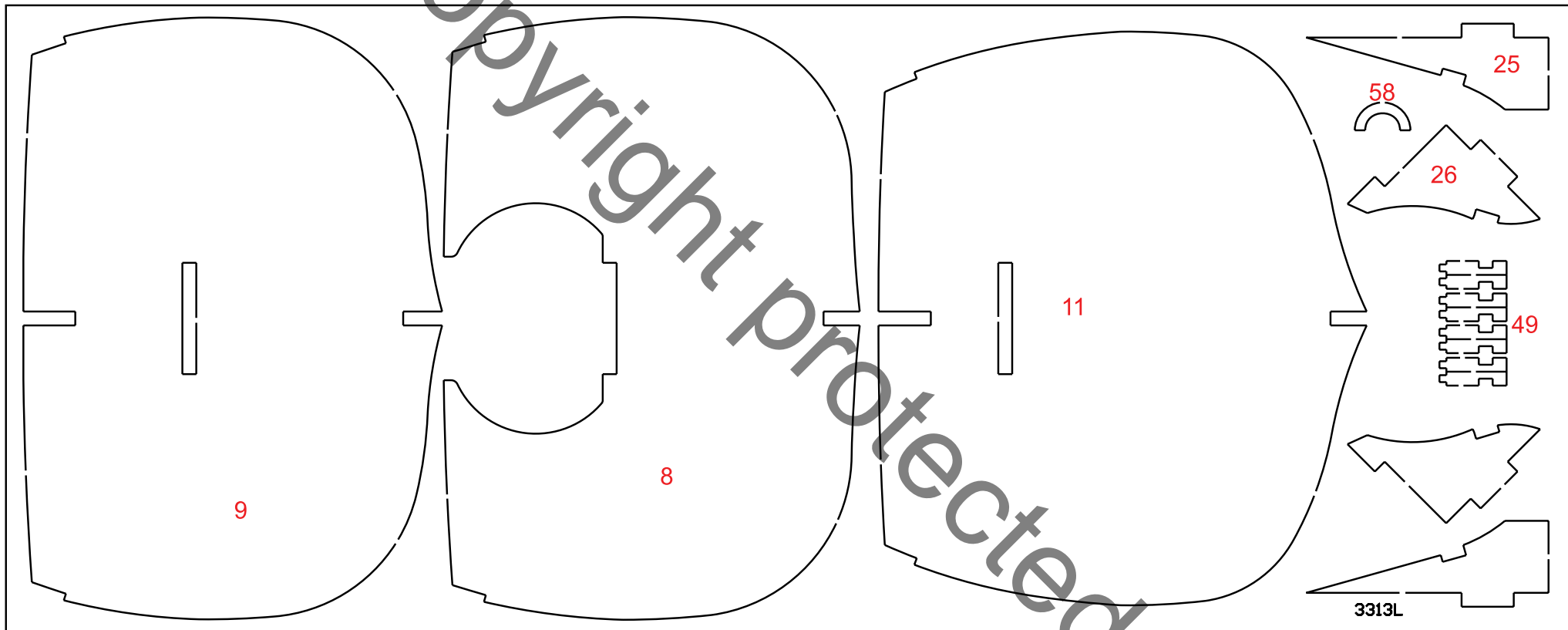

25

58

26

11

49

9

8

3313L

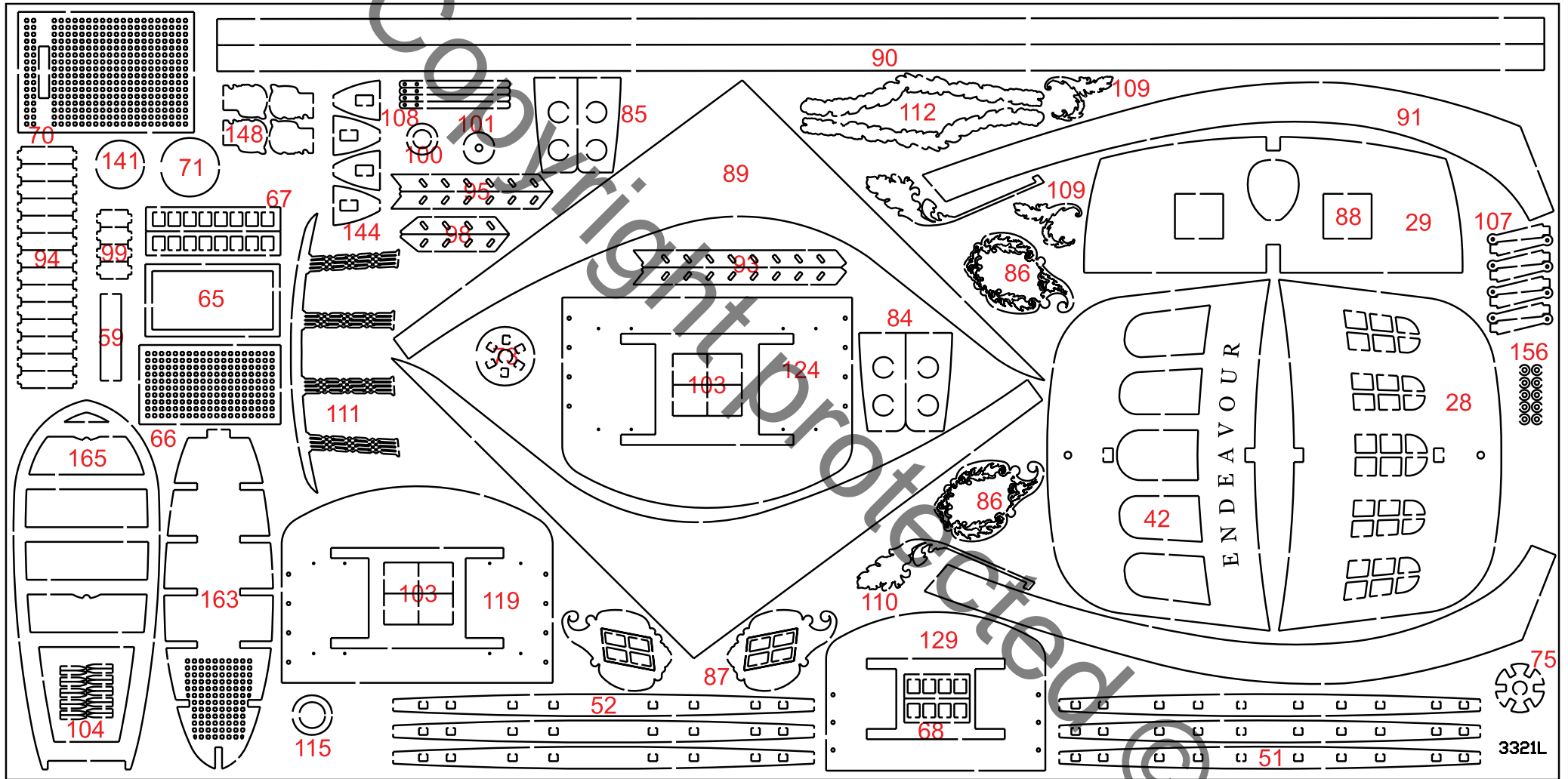



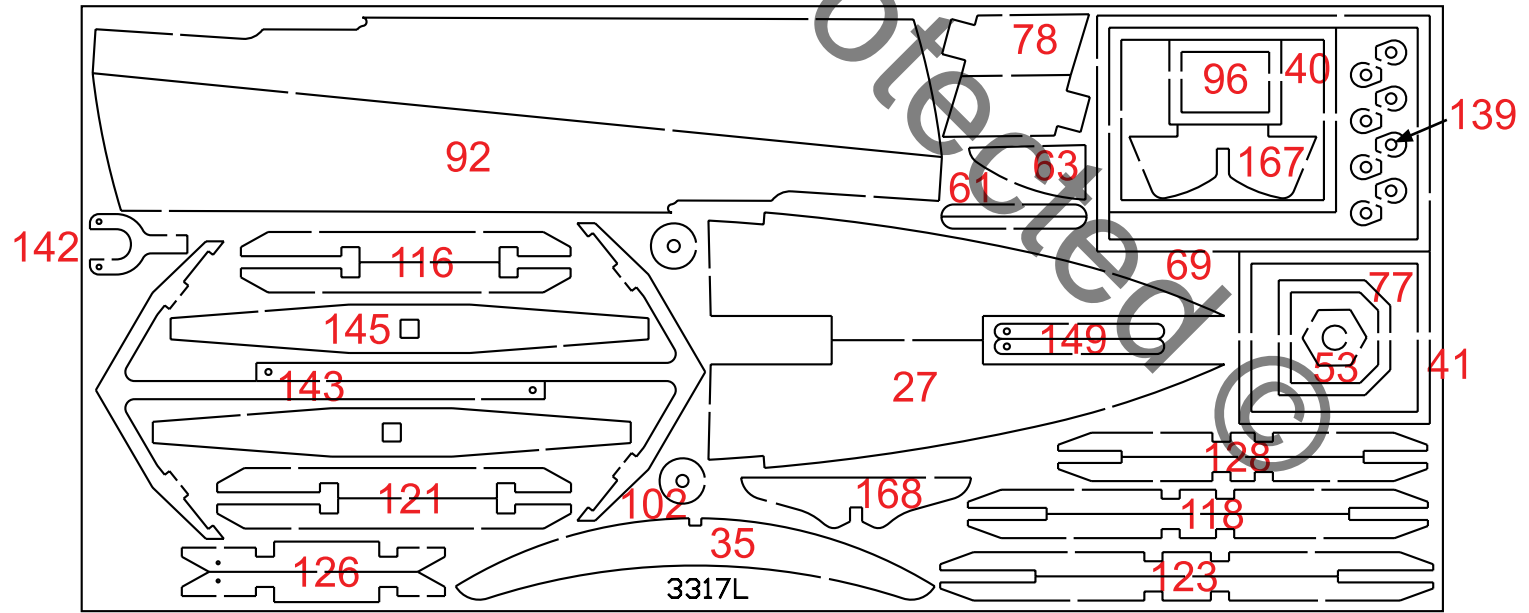
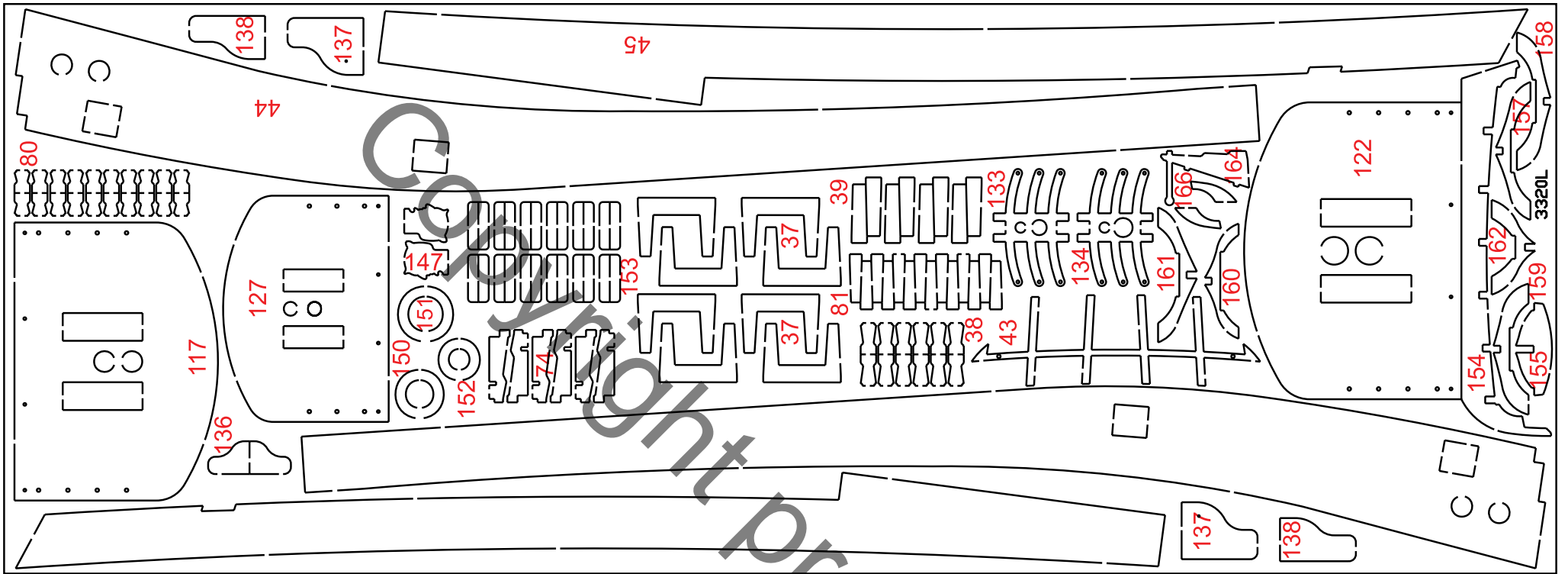

186

# HMS Endeavour 187

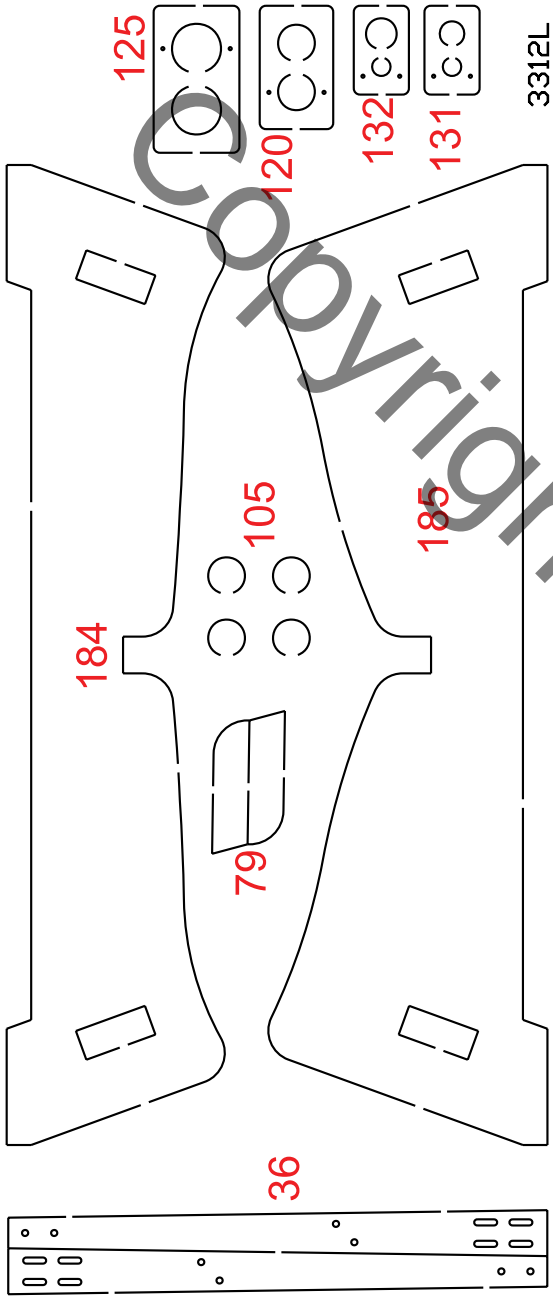

33

33

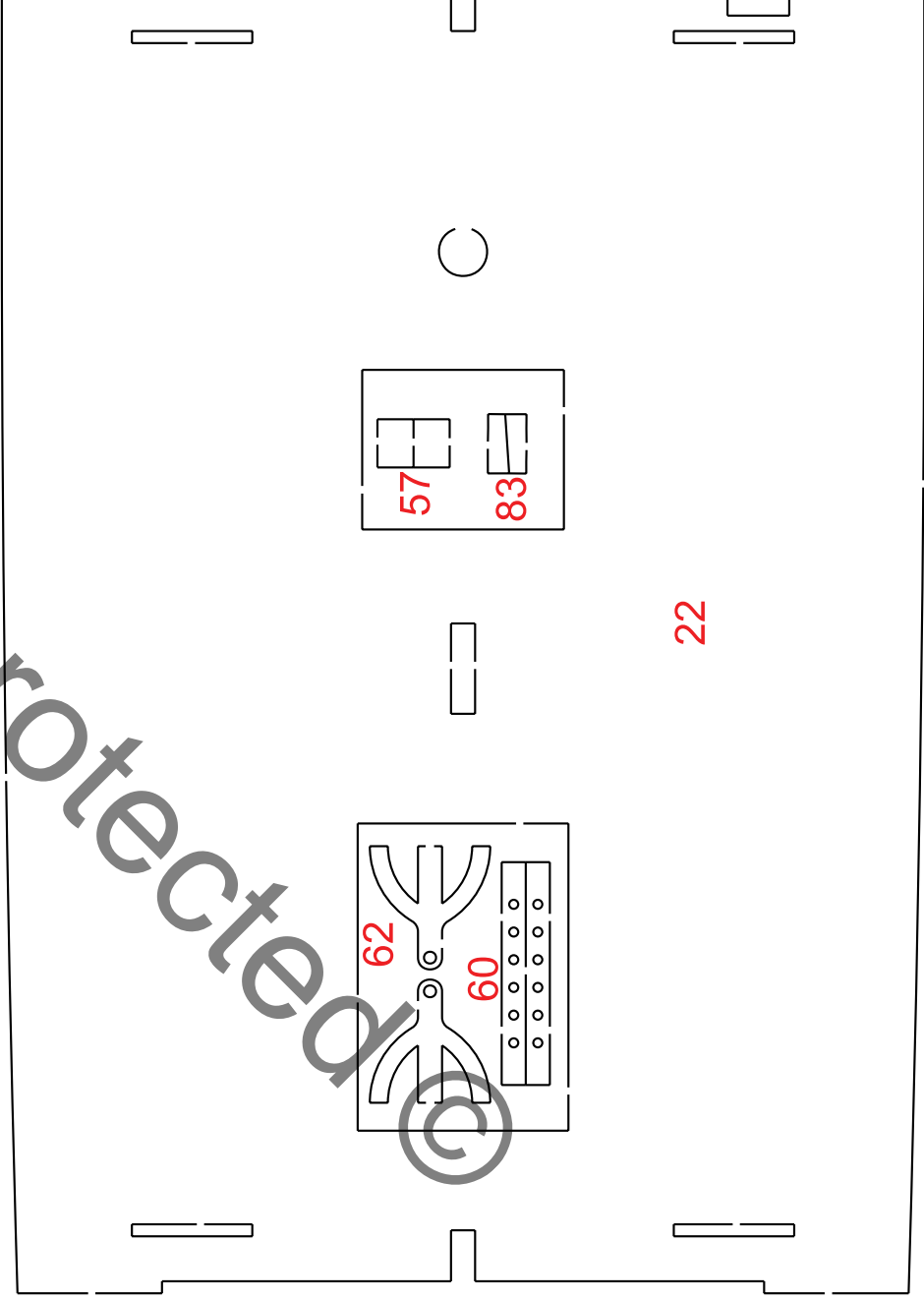

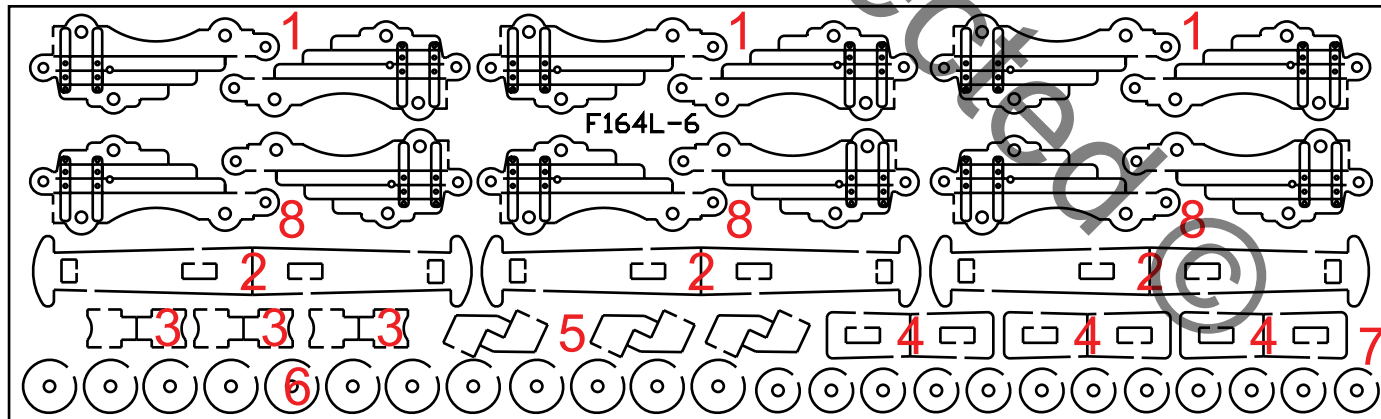
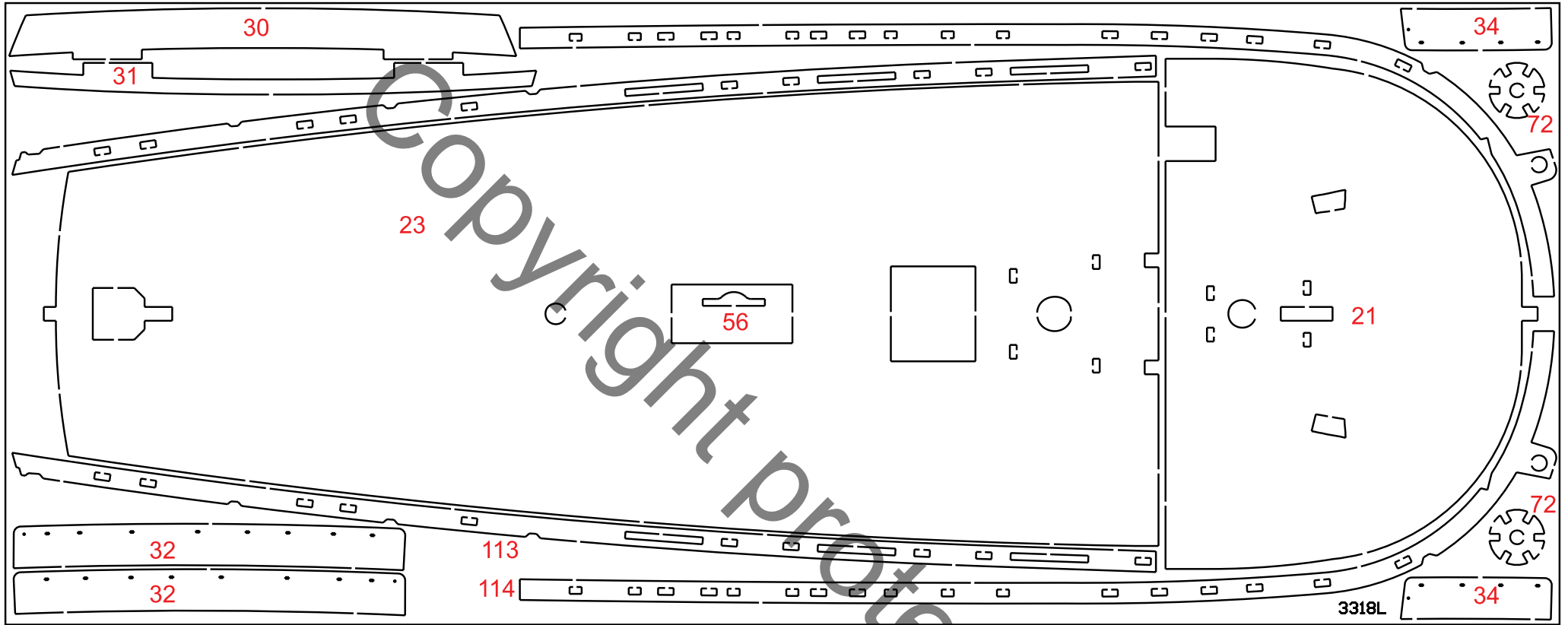
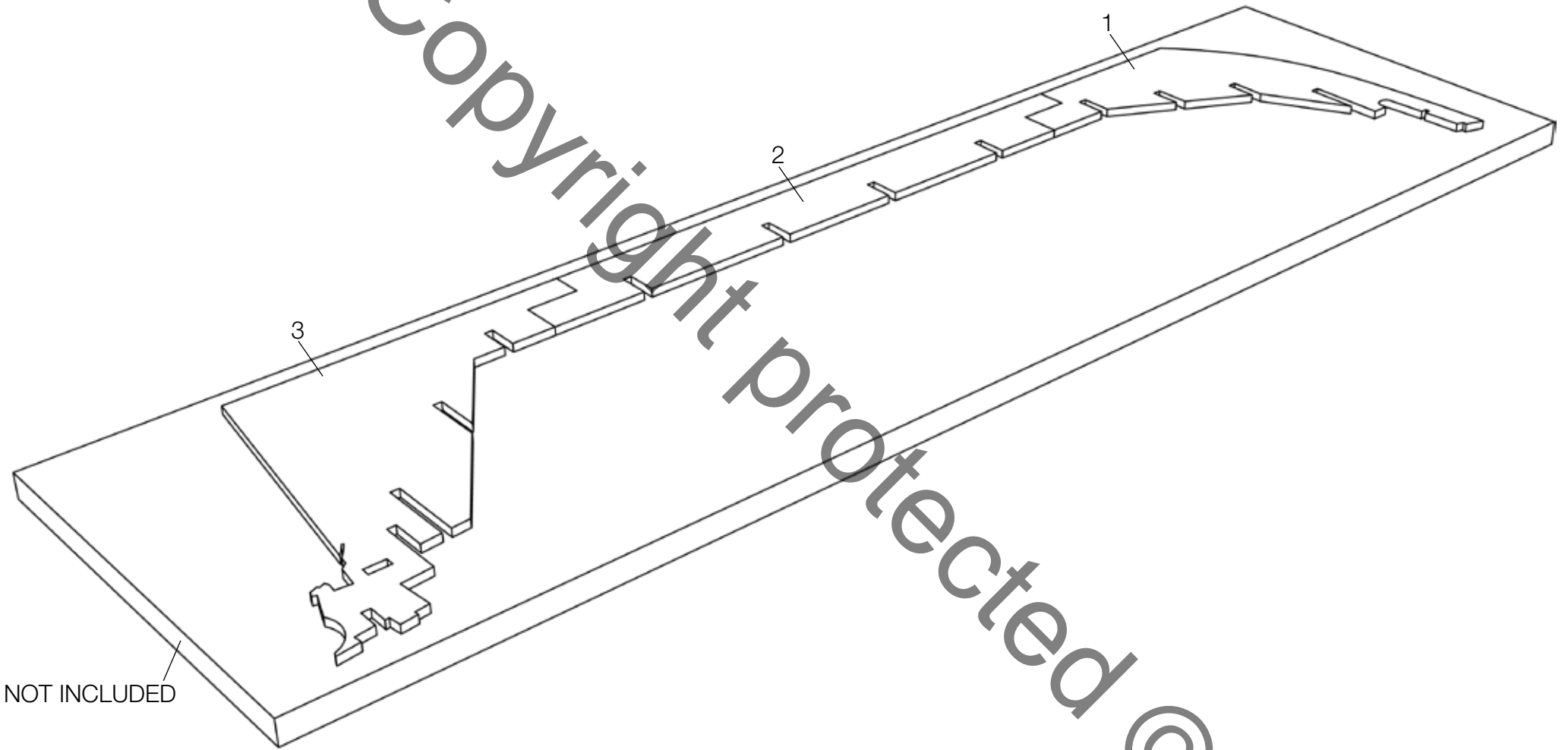

FIG. 1



NOT INCLUDED

Copyright protected ©

FIG. 2

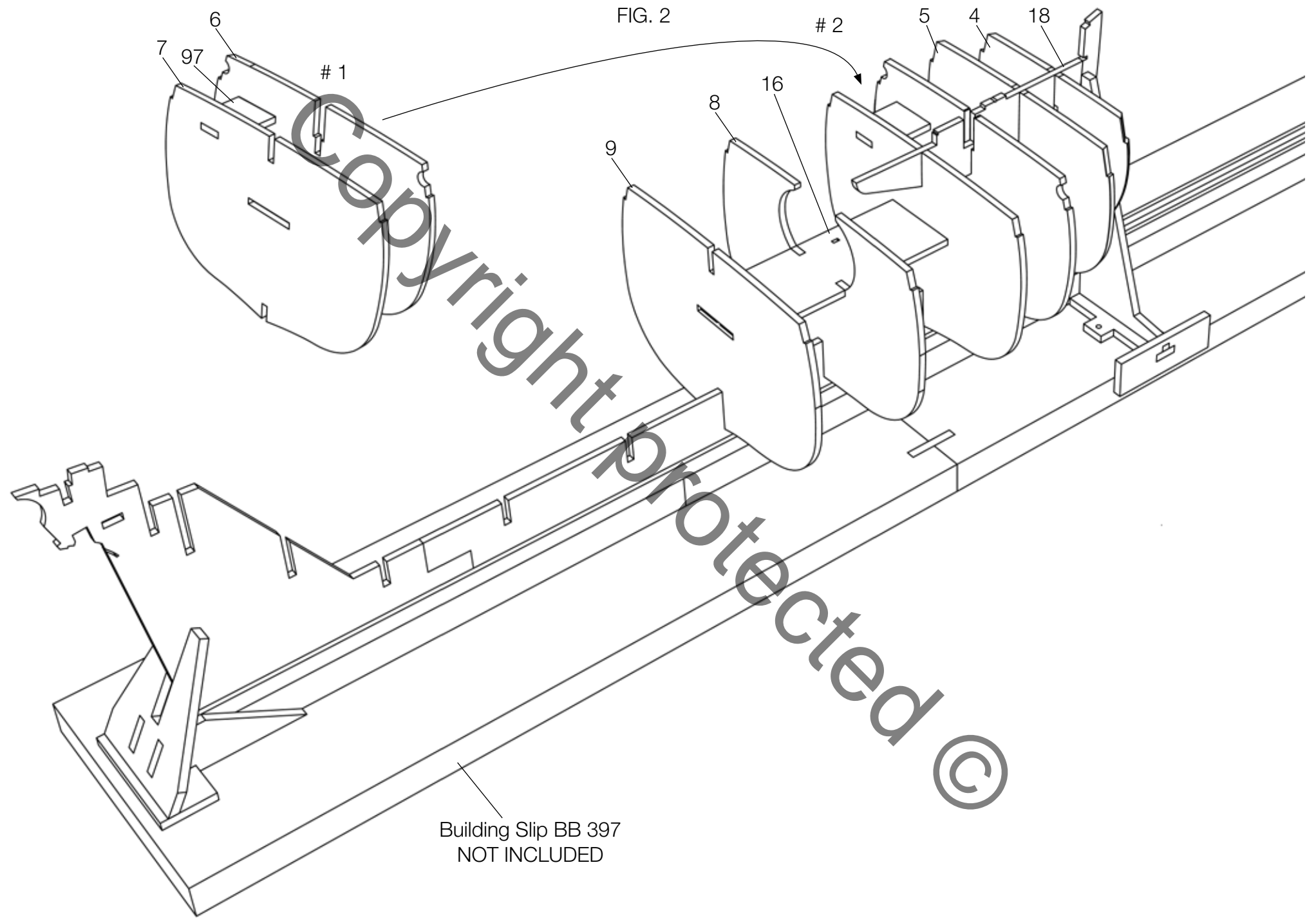

Building Slip BB 397  
NOT INCLUDED

FIG. 3

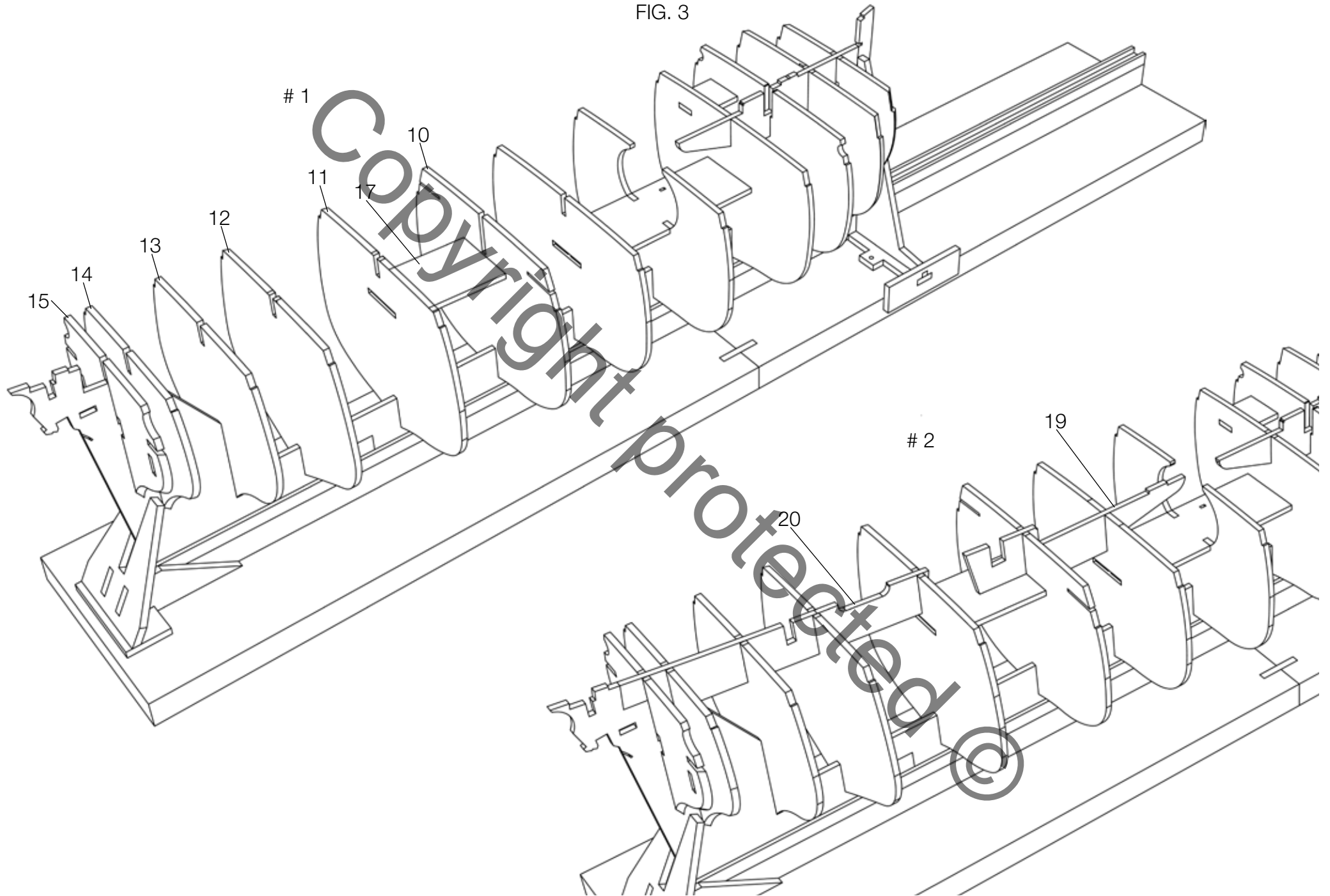

FIG. 4

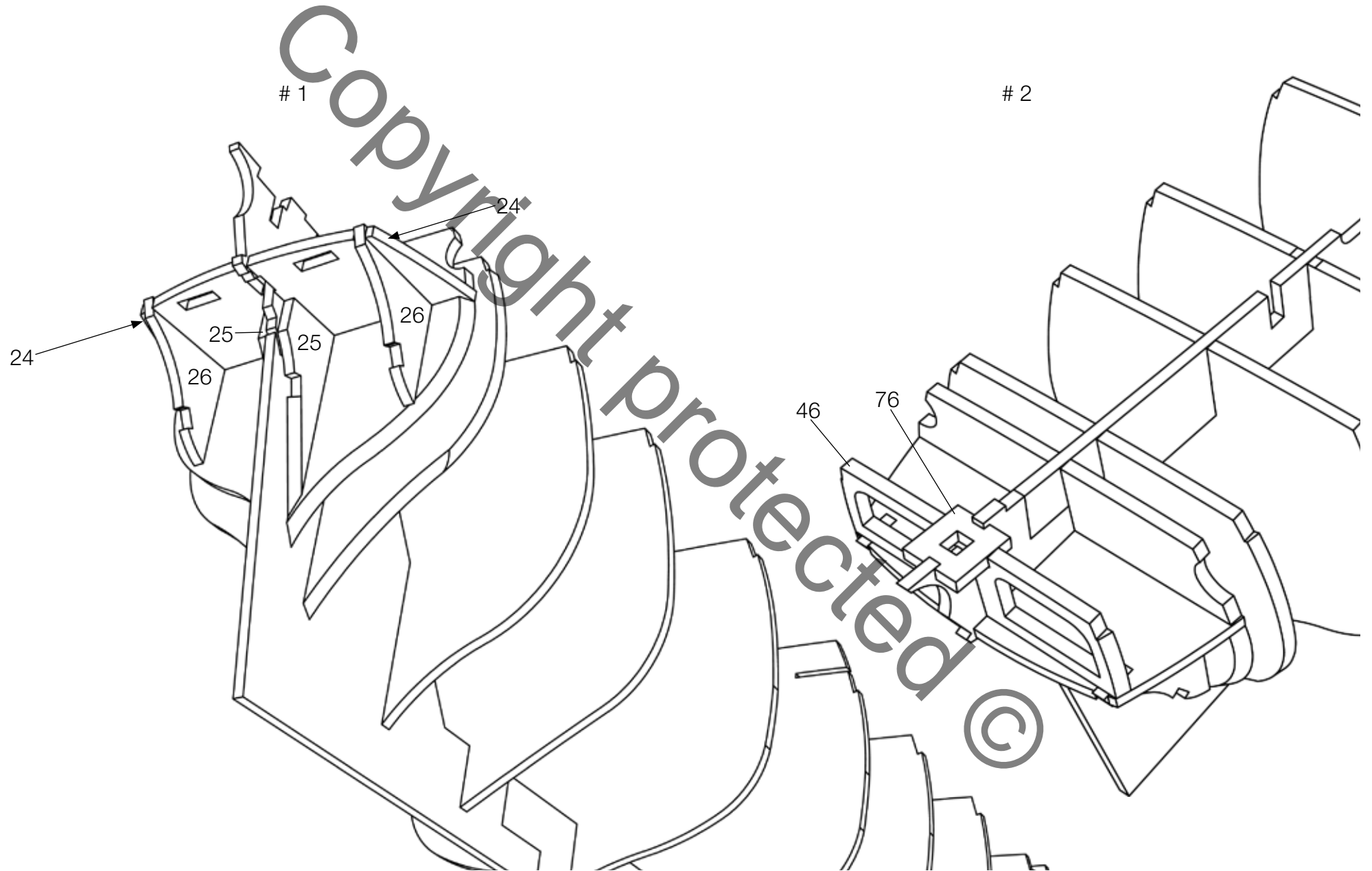



FIG. 5

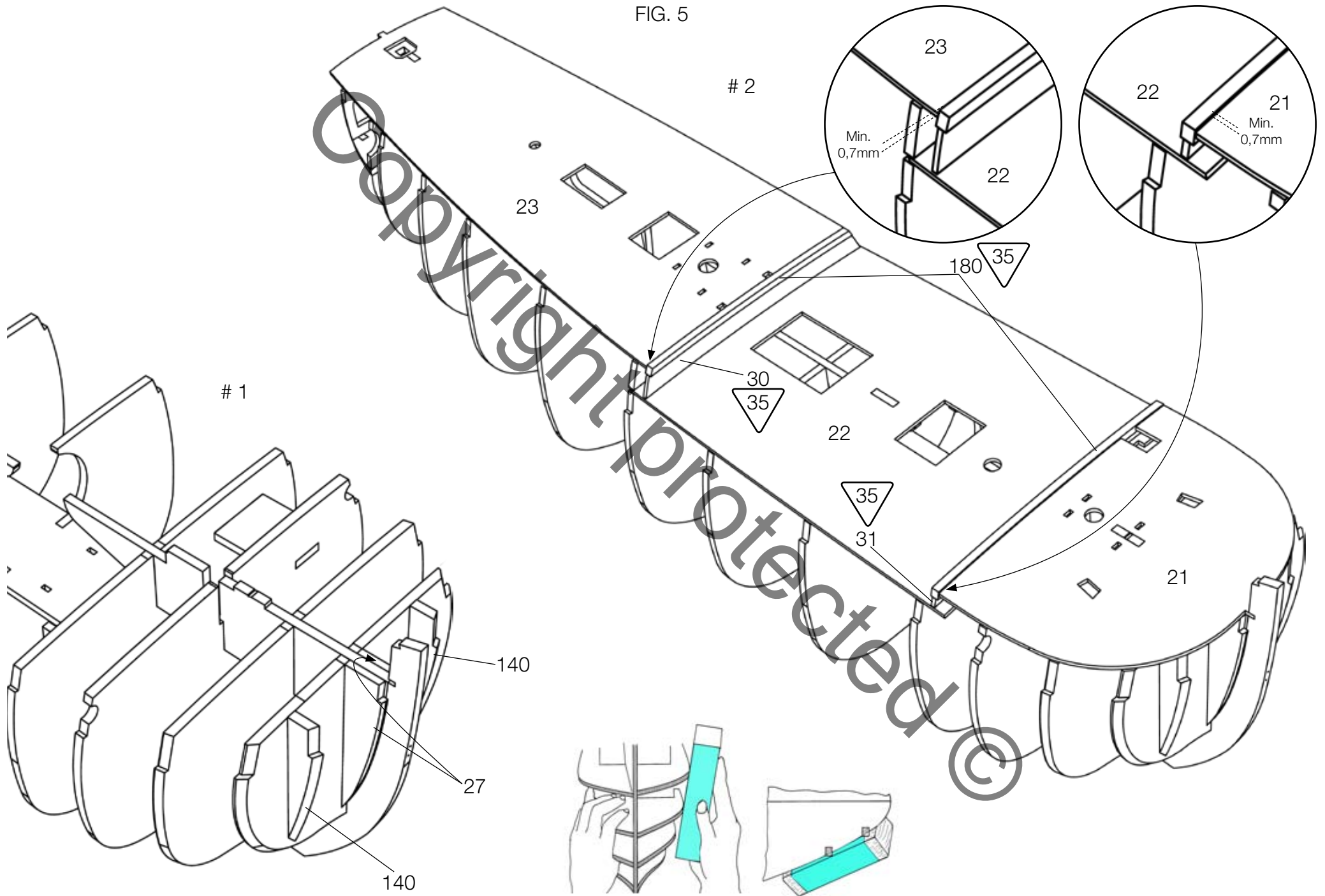



FIG. 6

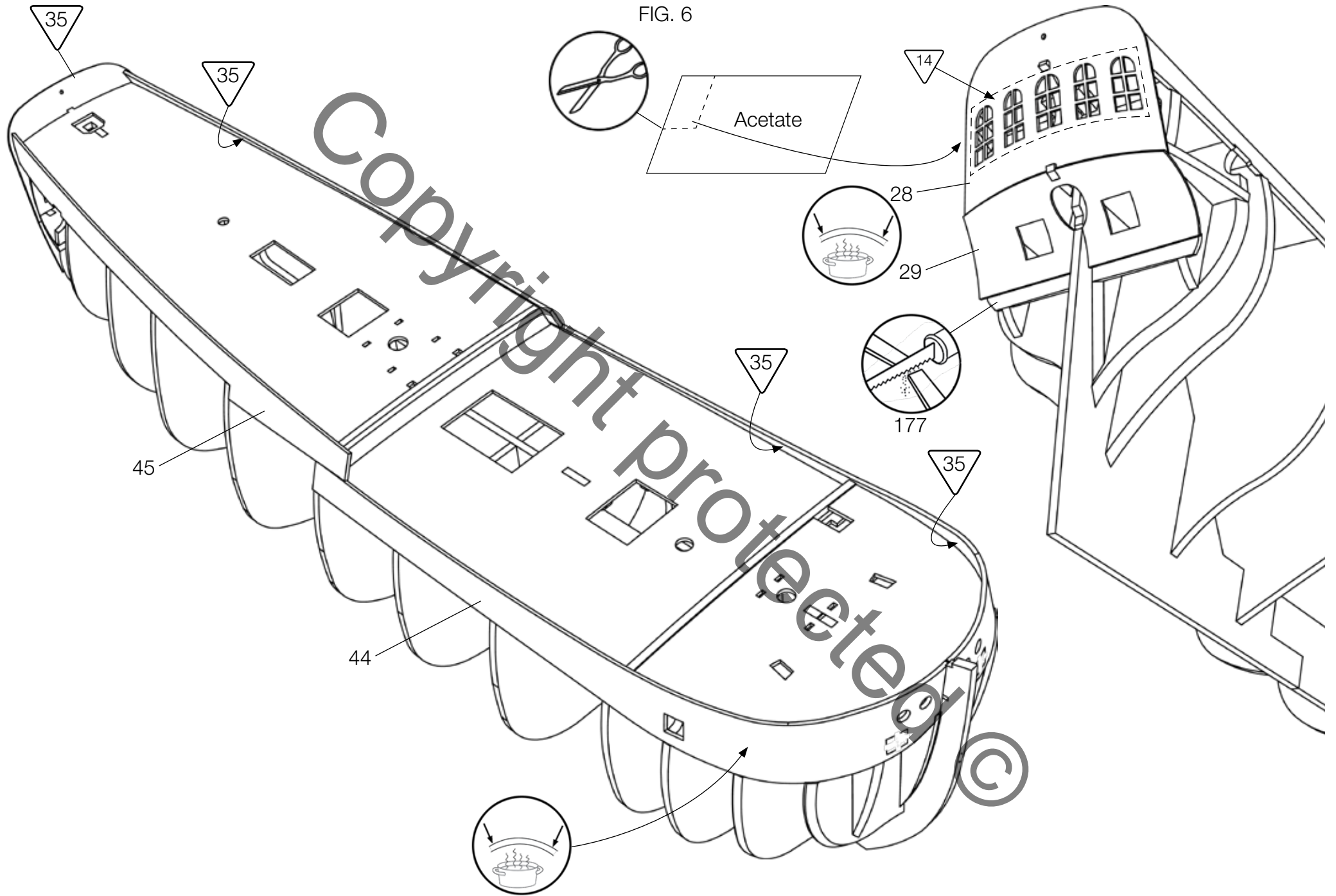

FIG. 7

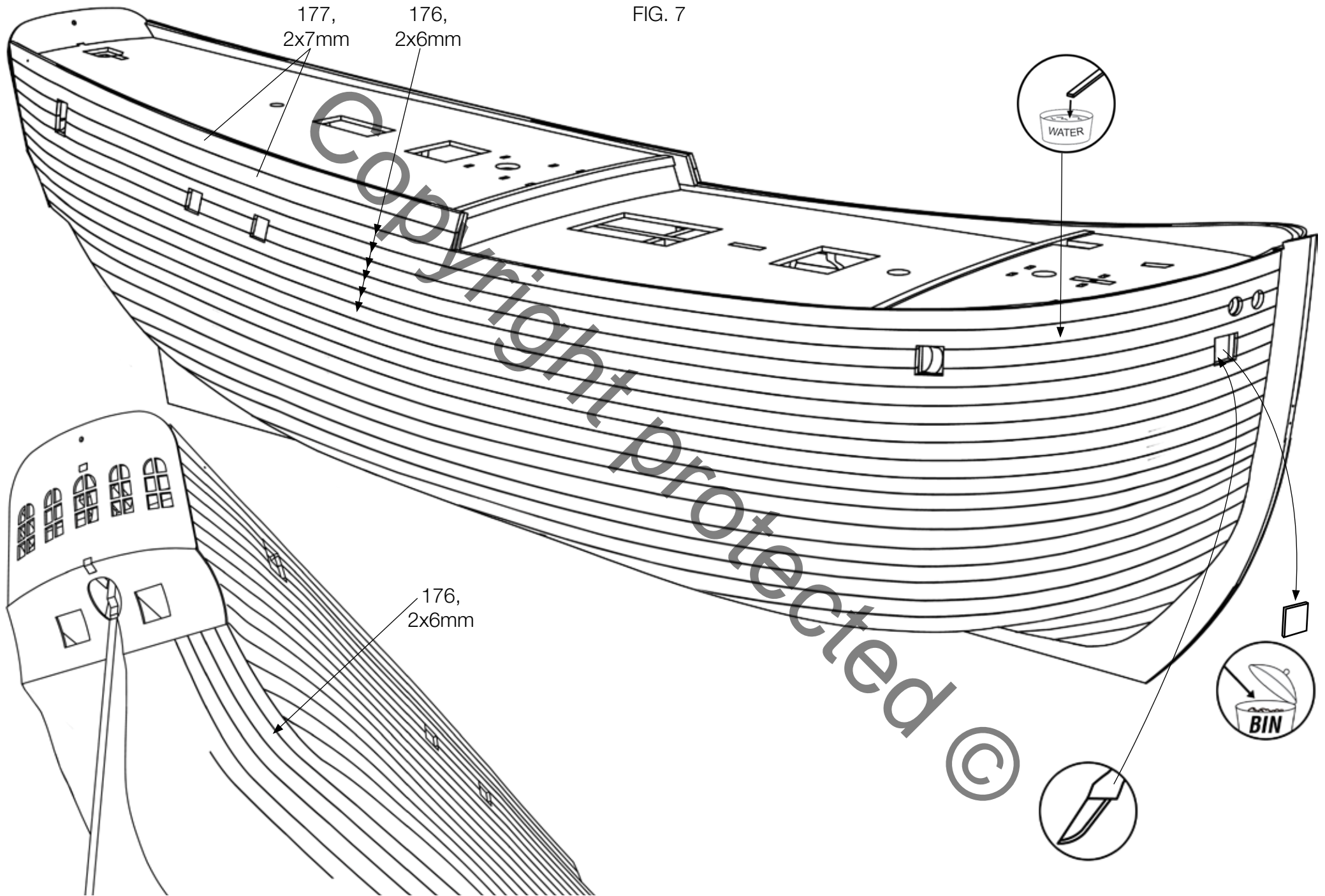



FIG. 8

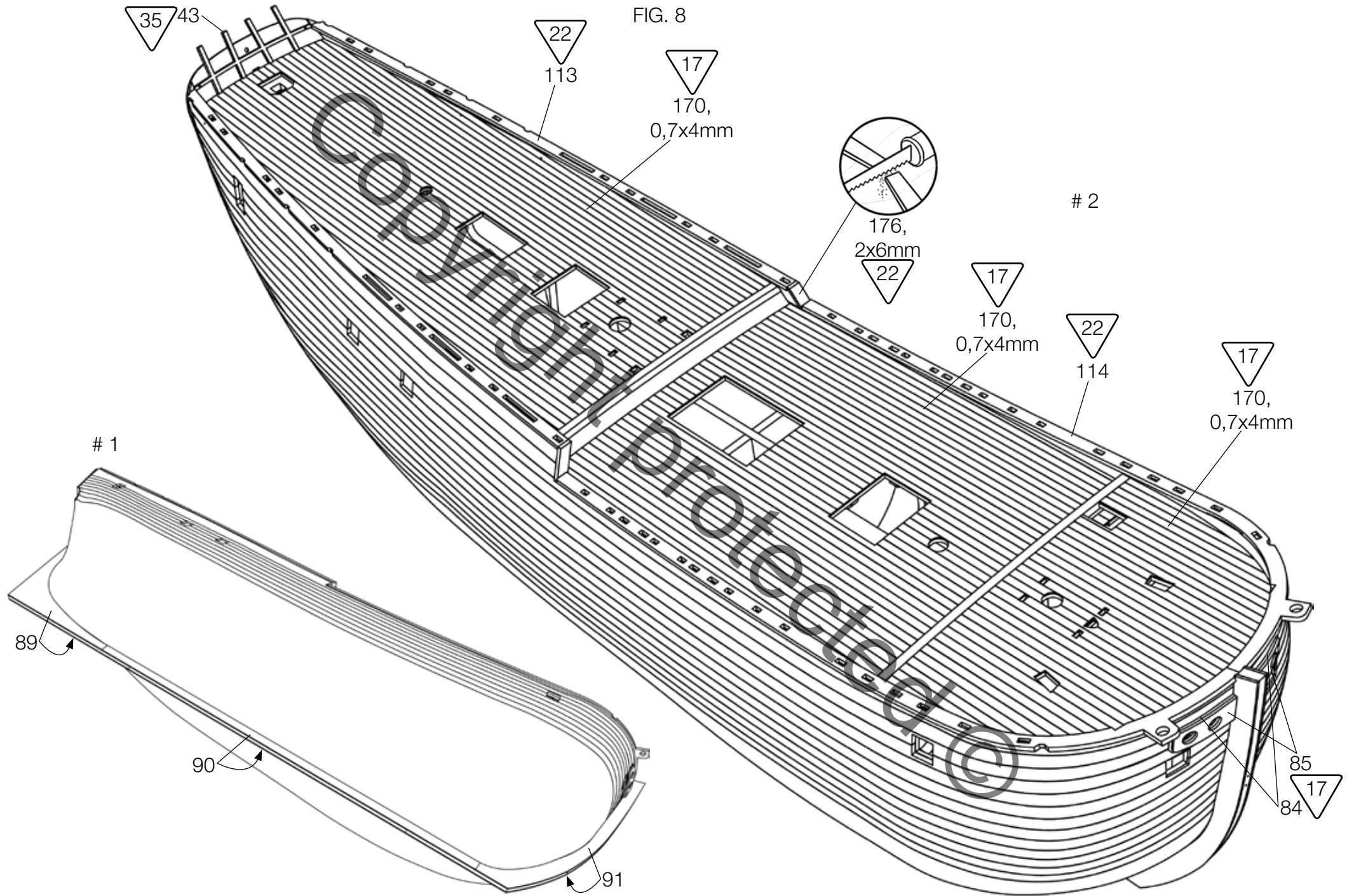

FIG. 9

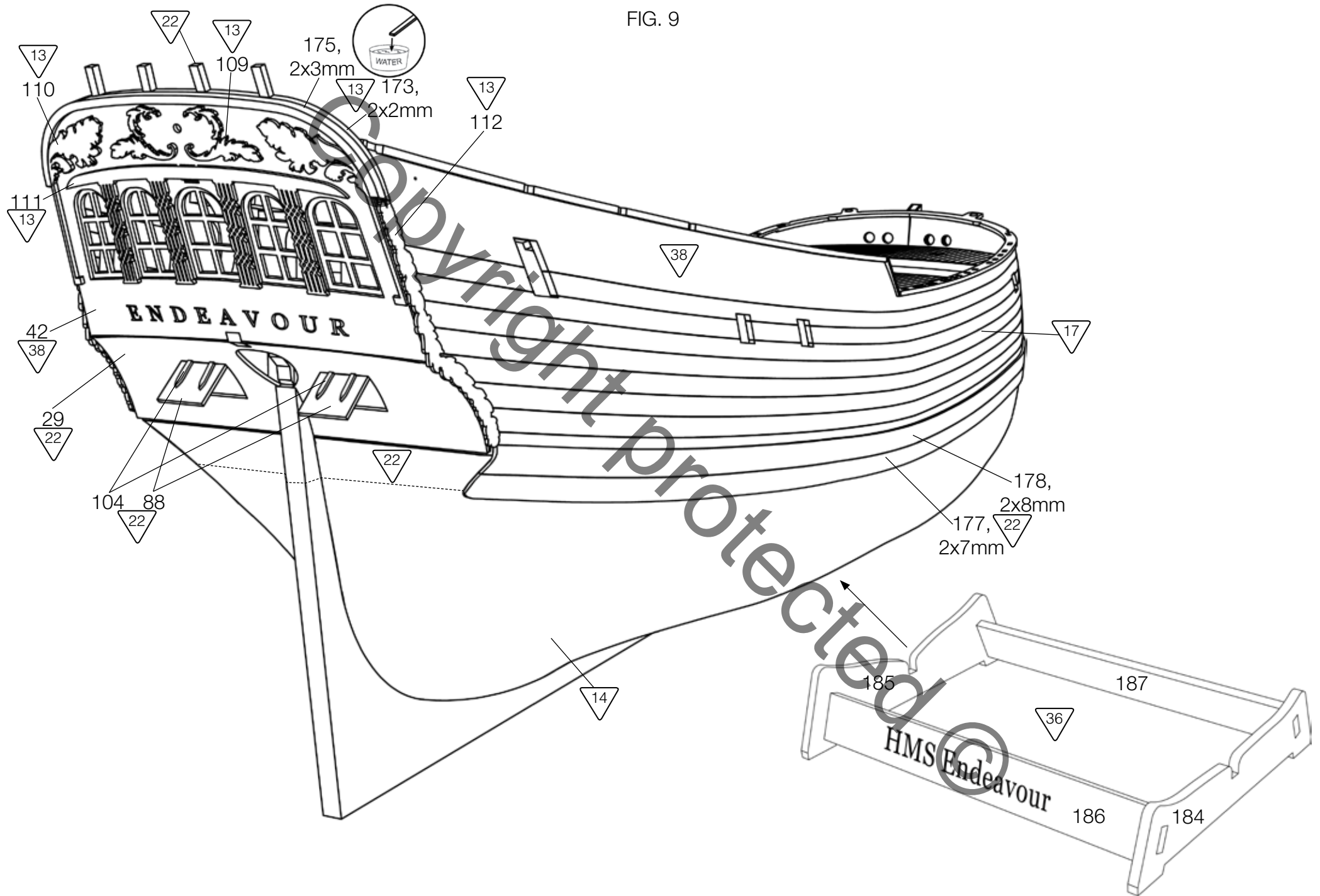



FIG. 10

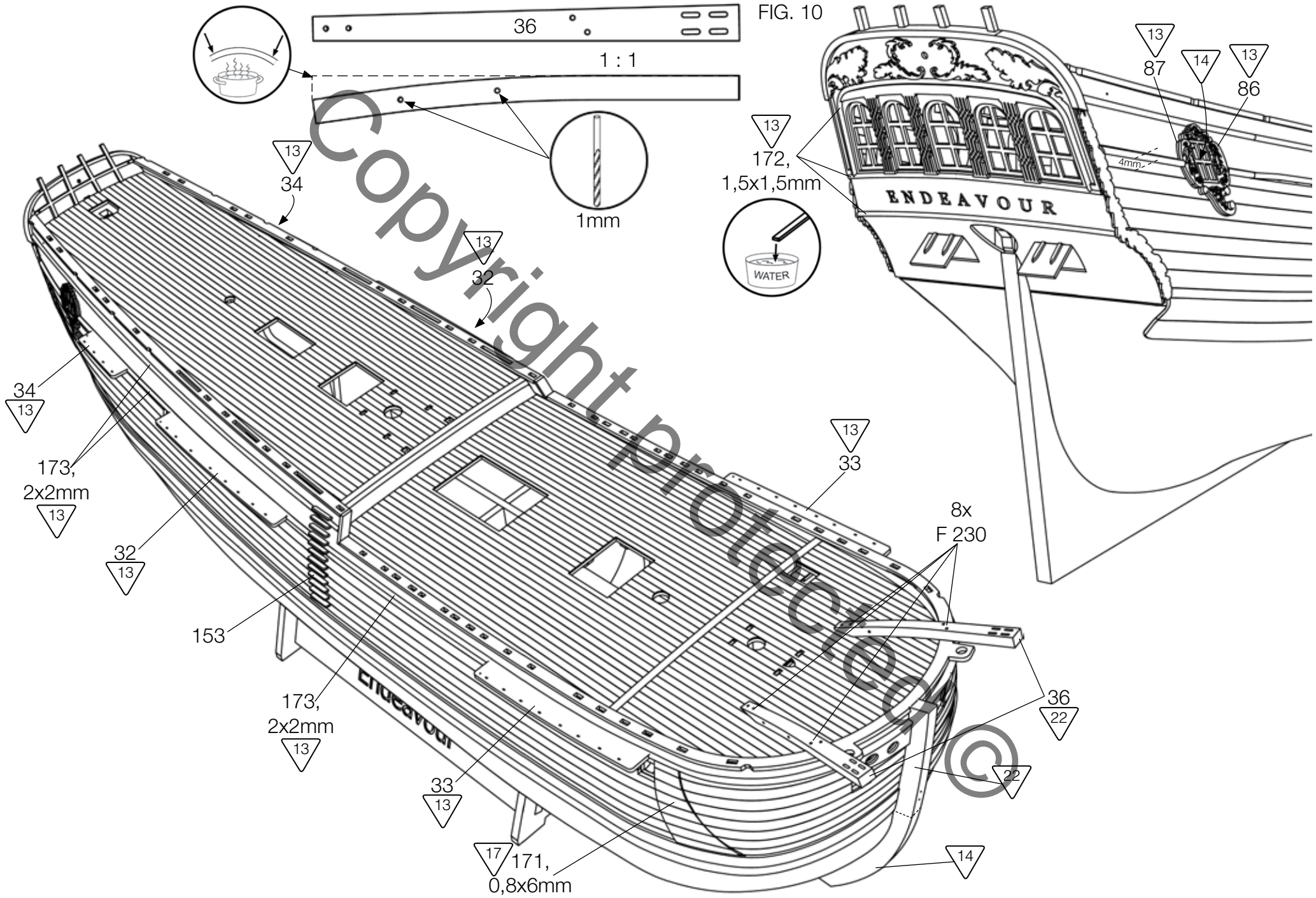
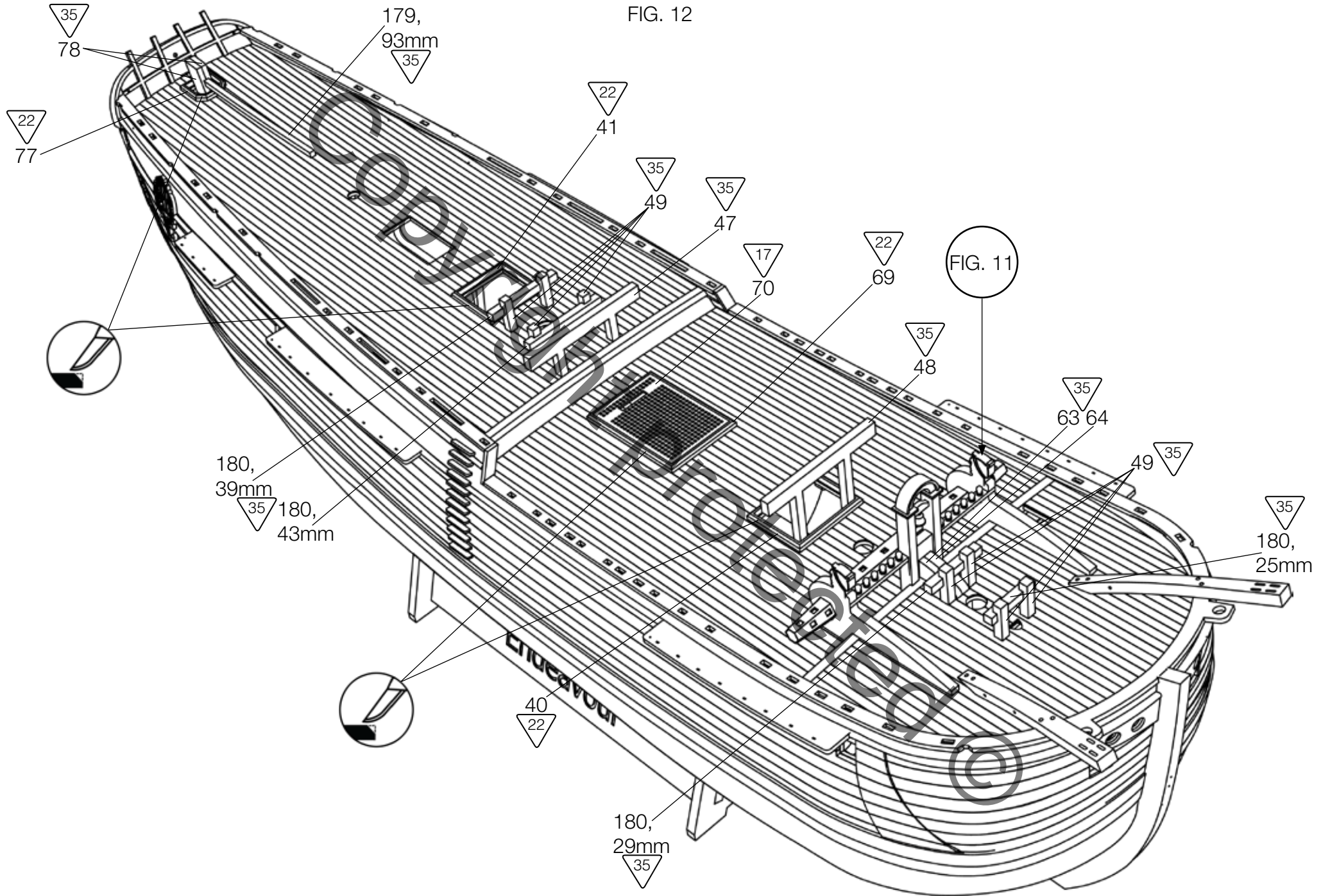





FIG. 12





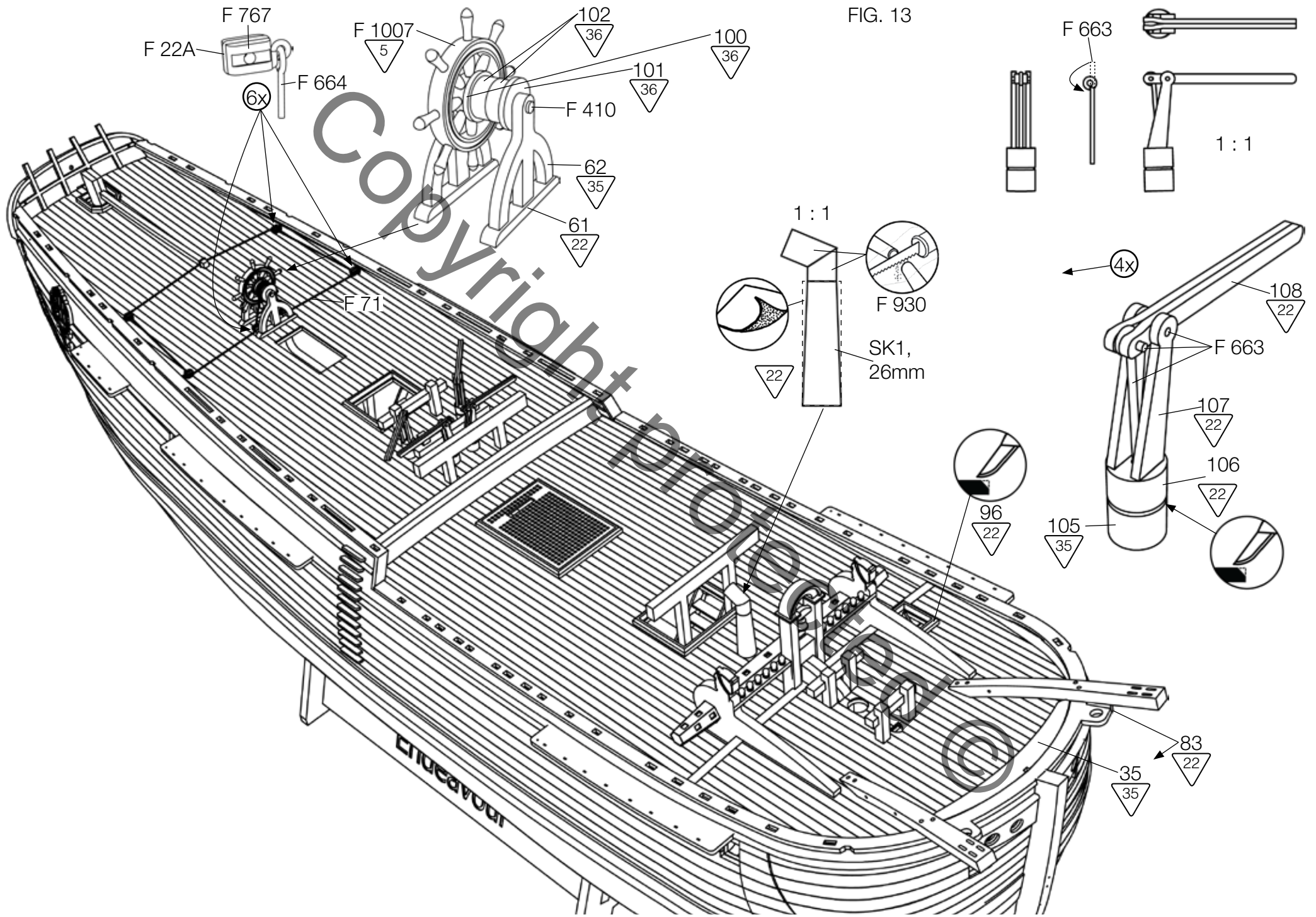

FIG. 13

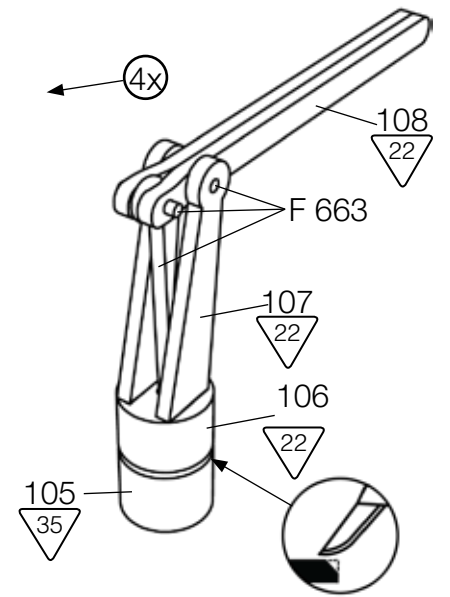
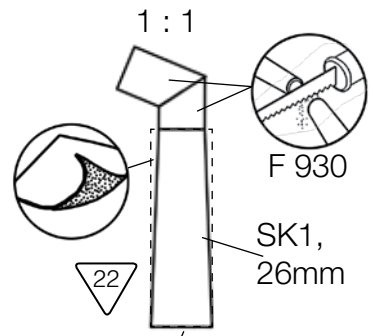
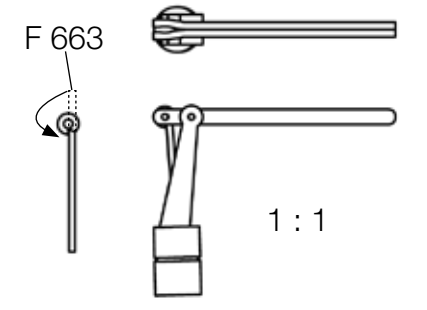



FIG. 14

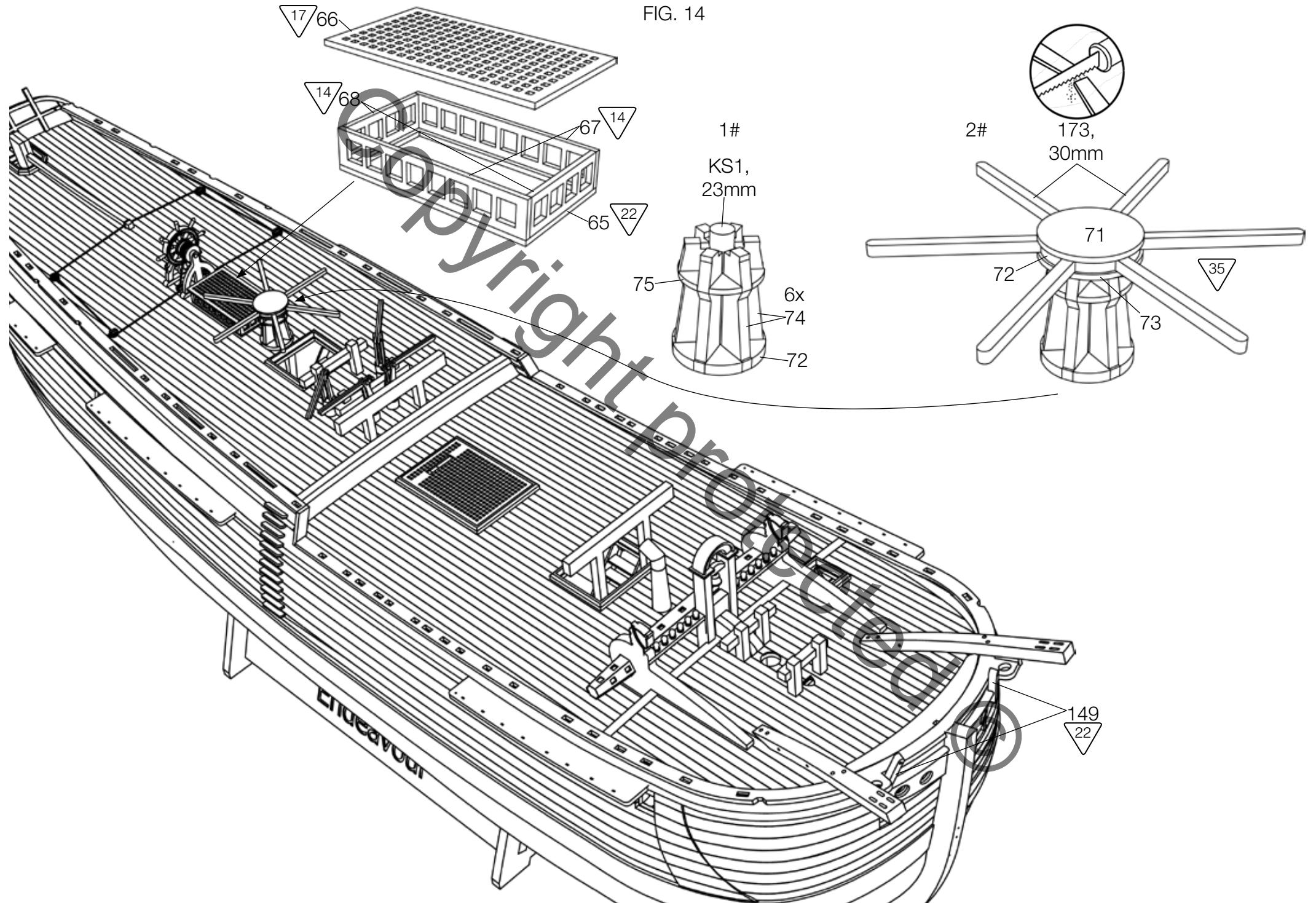
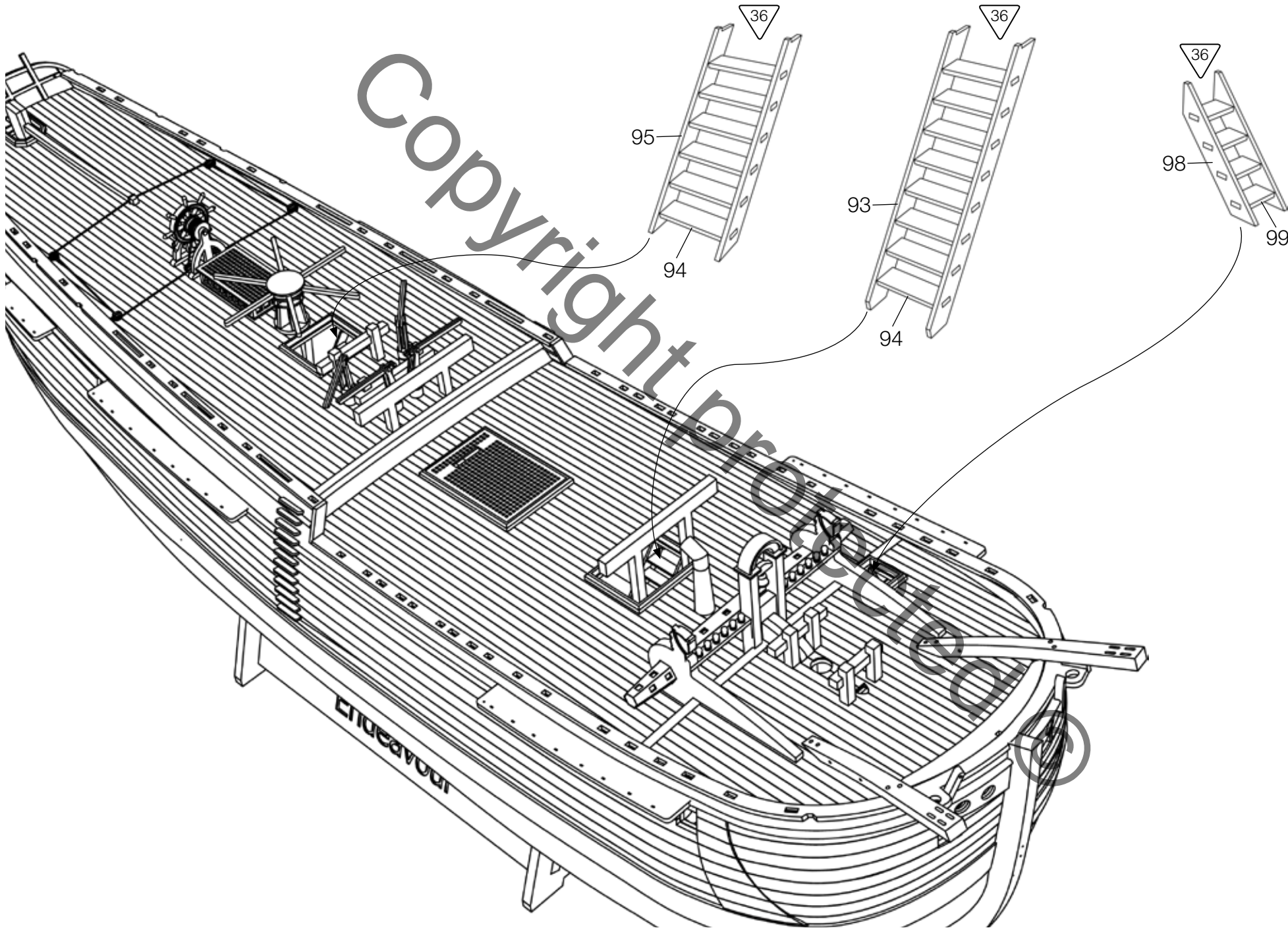



FIG. 15





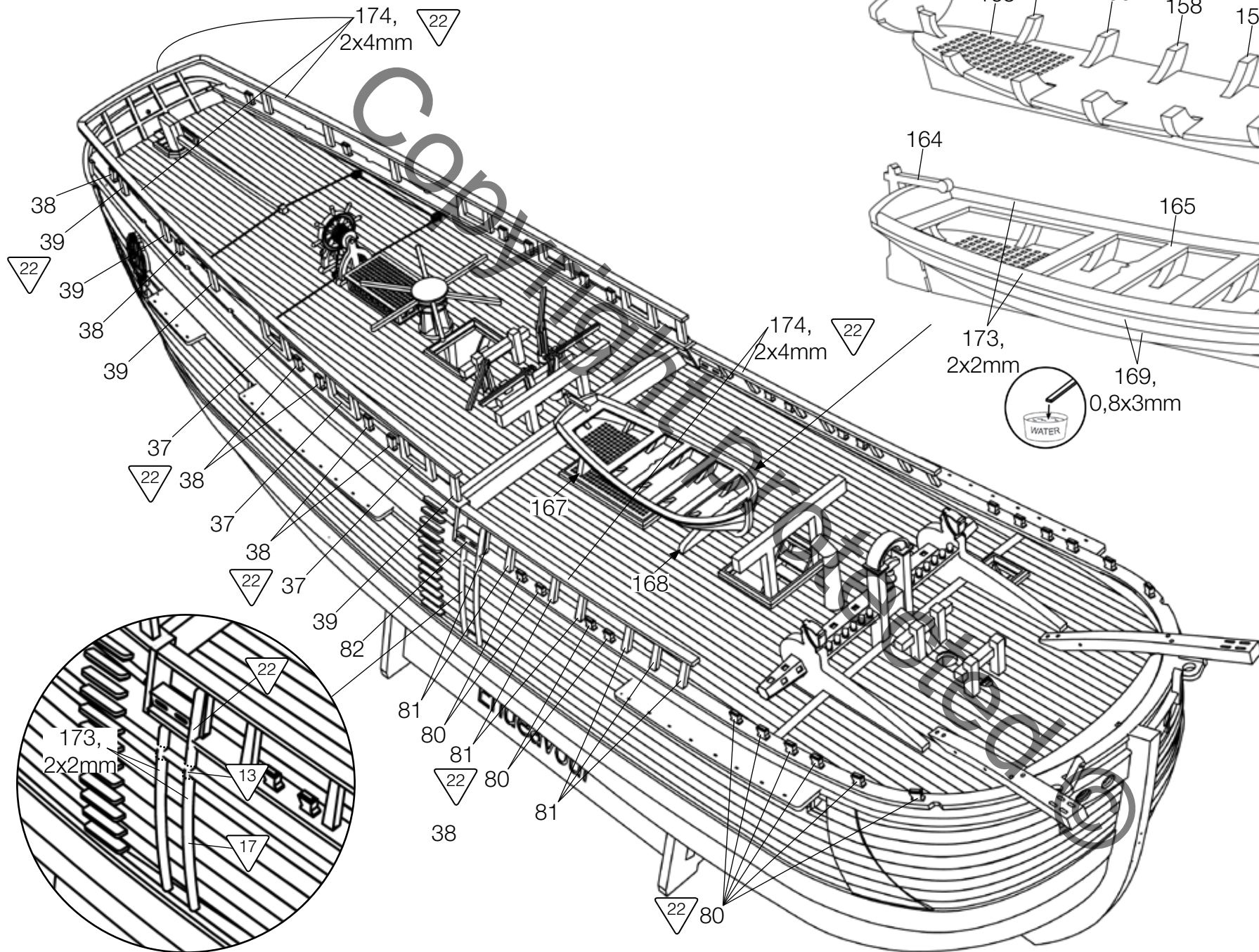
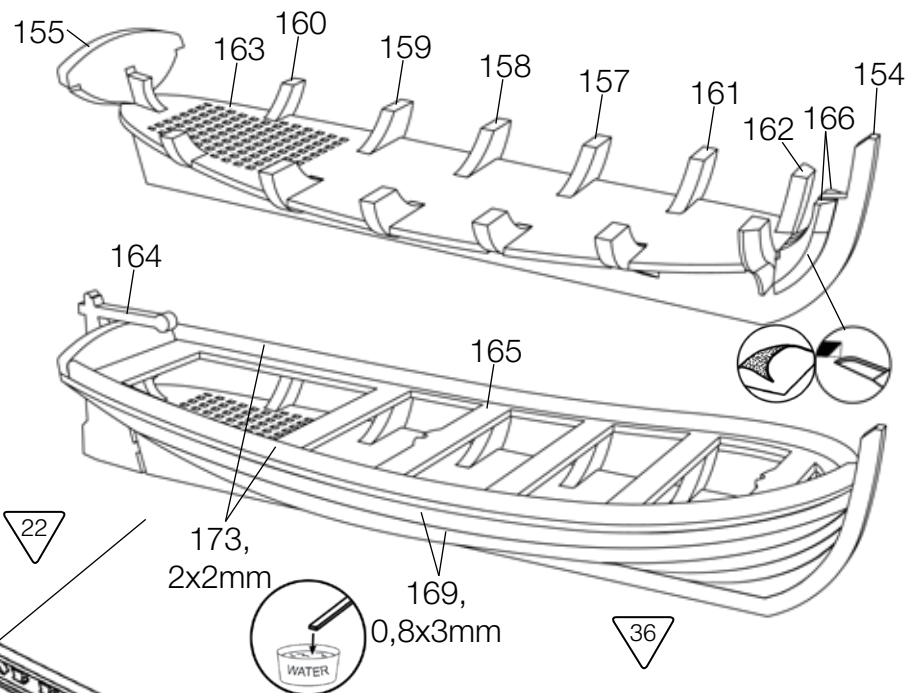

FIG. 16





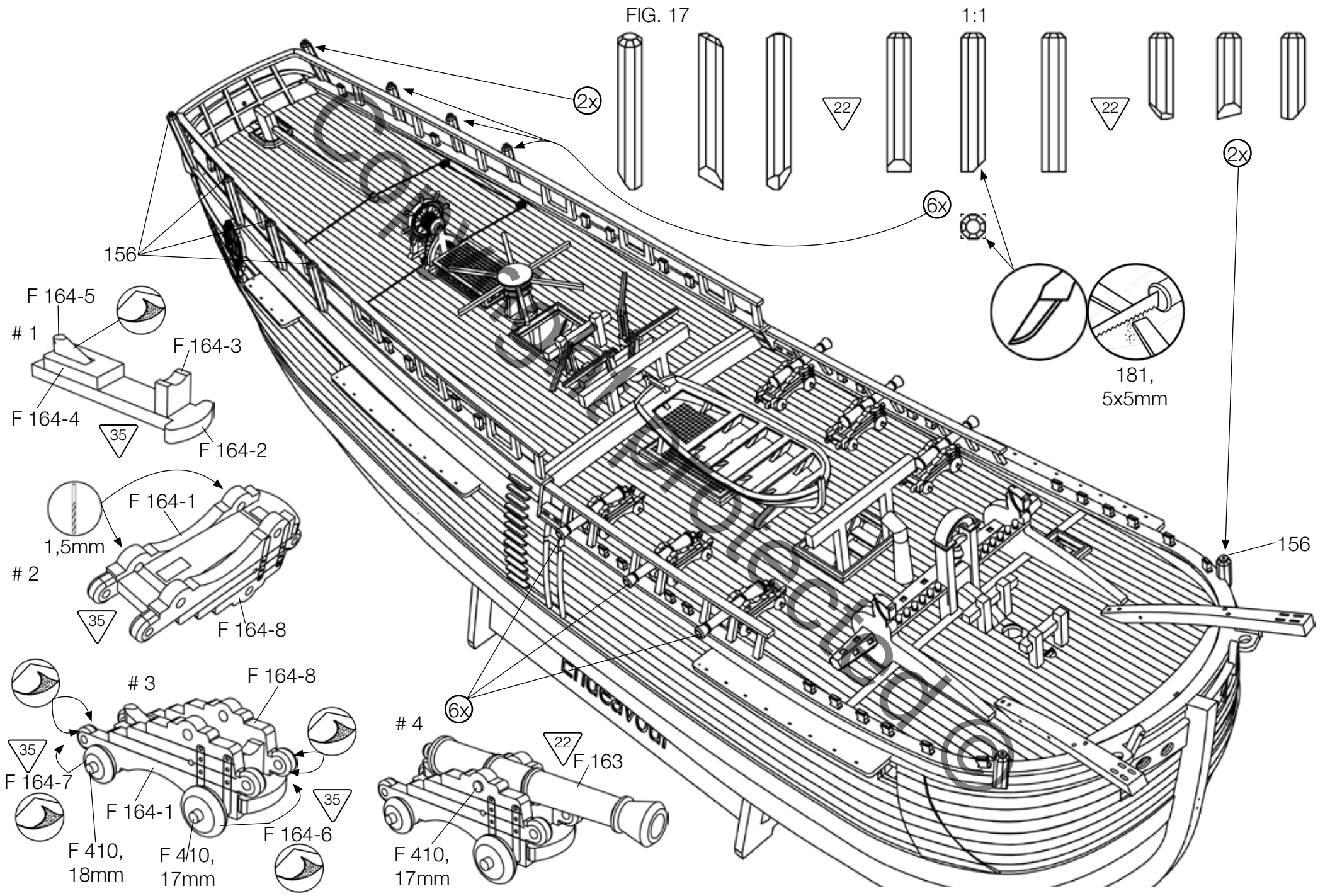



FIG. 18

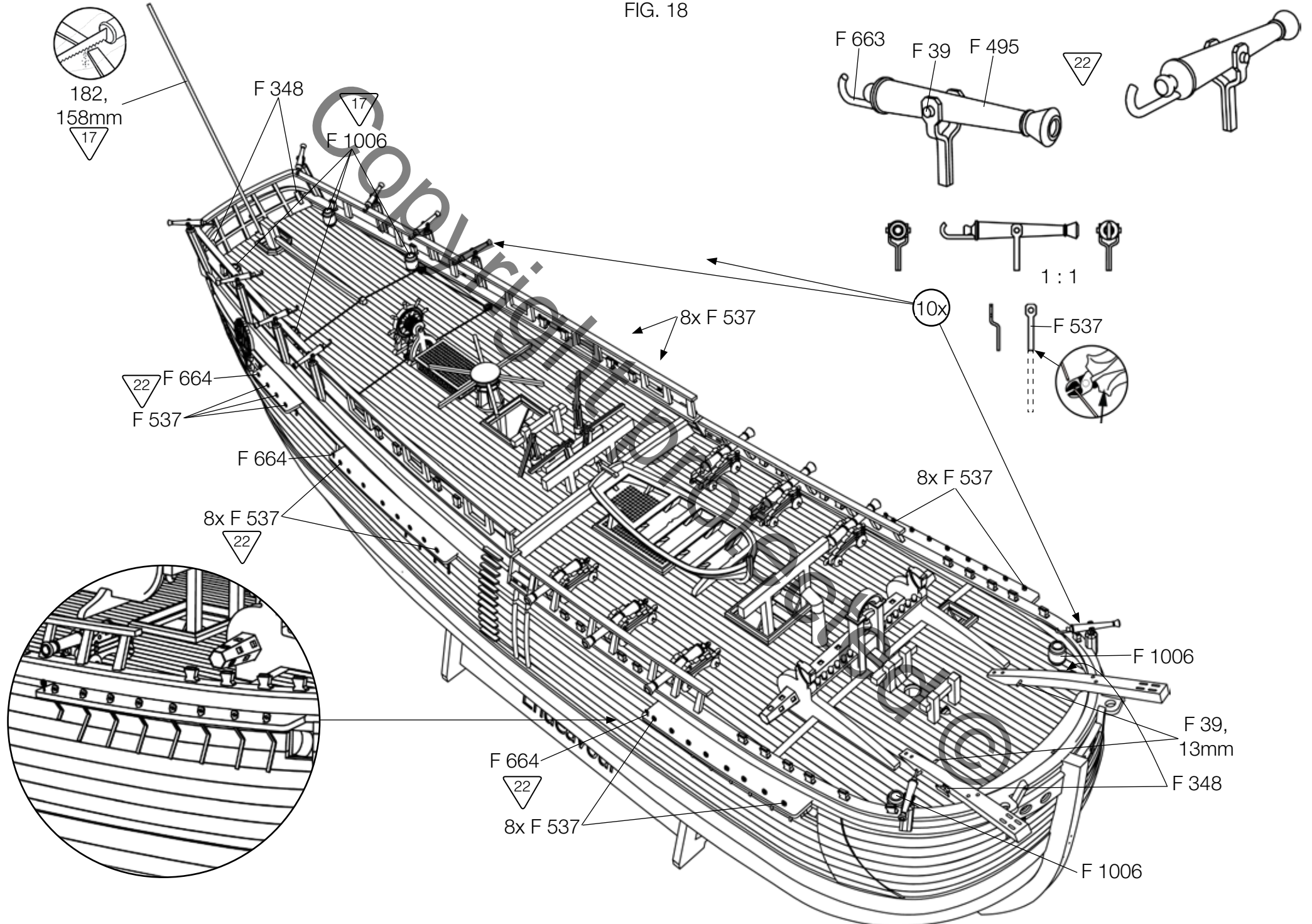

FIG. 19

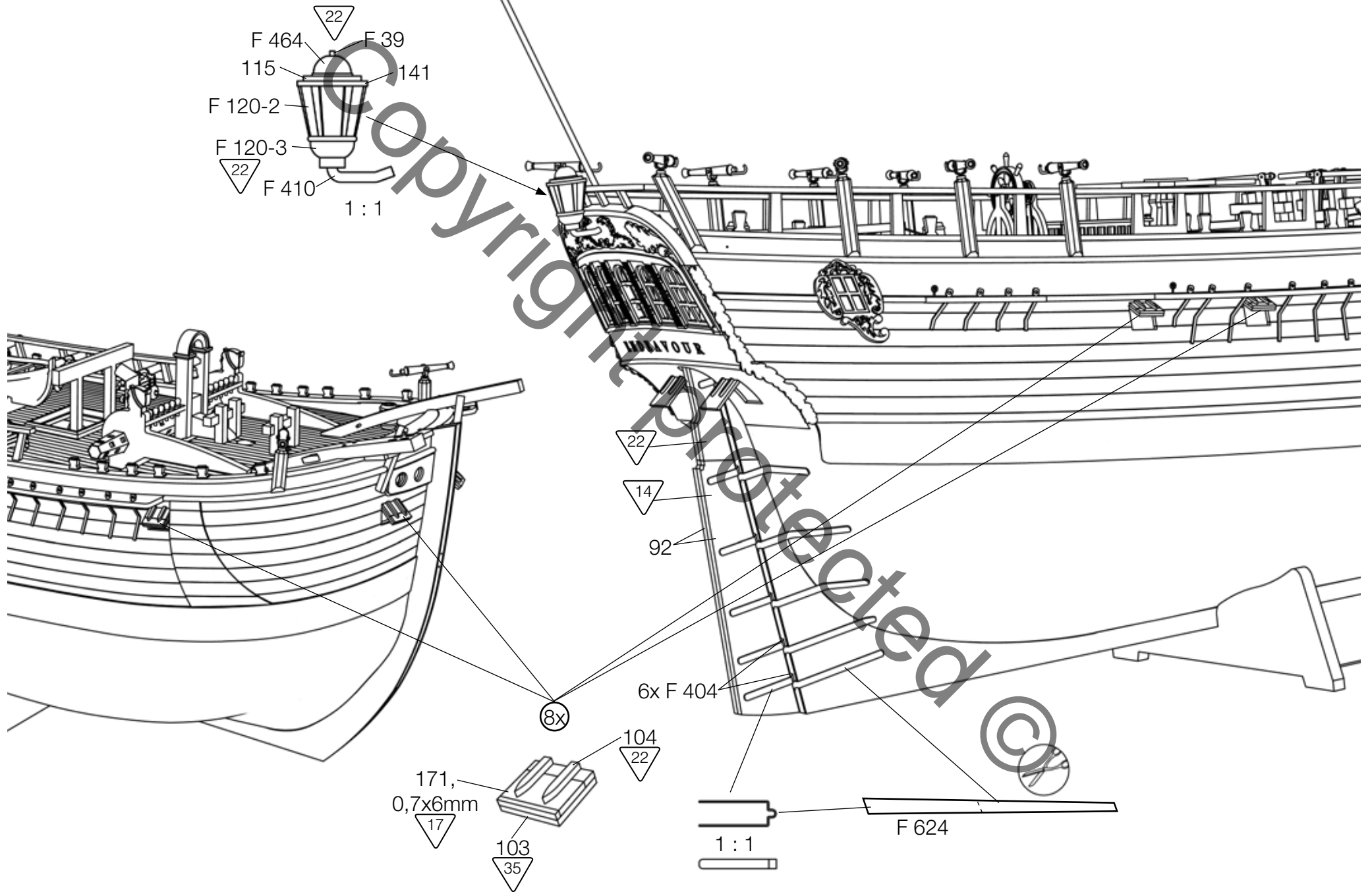
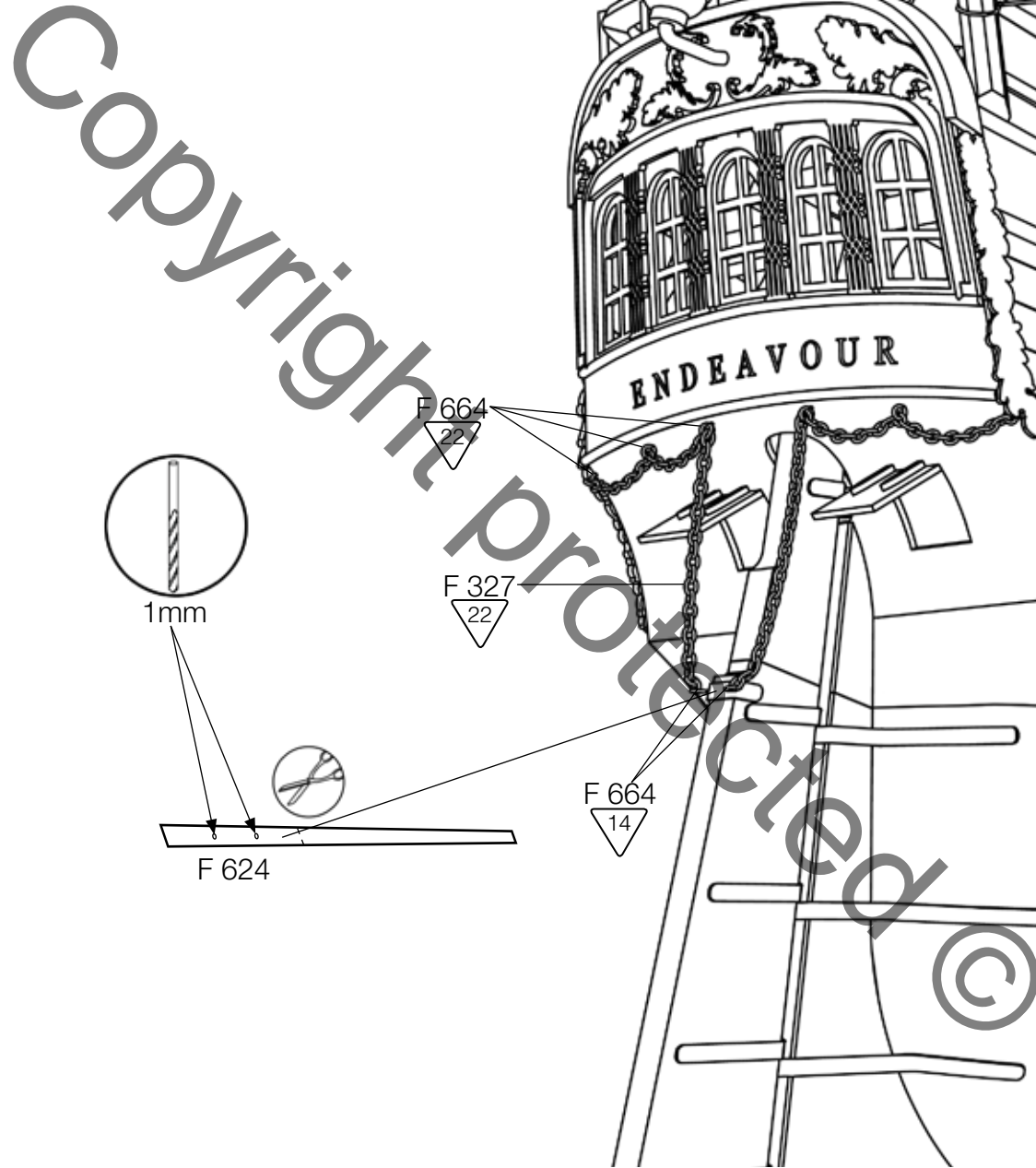

FIG. 20



→ Mast drawing



FIG. 21

